



SUPER DUTY 7+4 EH FORAGE BOX

PARTS BOOK



Revision #01
Starting Serial #410112

HSMFG0414

Part #63772

**Manufactured By
H&S MANUFACTURING CO.,INC.**

**P.O. BOX 768 (715) 387-3414 FAX (715) 384-5463
MARSHFIELD, WISCONSIN 54449**

CONTENTS

Instructions for Ordering Parts	1
Figure 1 - Housing Components (Sides)	2-3
Figure 2 - Housing Components (Front and Bottom)	4-5
Figure 3 - Beaters	6-9
Figure 4 - Apron Drive	10-13
Figure 5 - Cross Apron Drive	14-15
Figure 6 - Extension	16-17
Figure 7 - Hydraulic Drive	18-19
Figure 8 - Beater Clutch	20-21
Figure 9 - Motor Mount	22-23
Figure 10 - Shields	24-25
Figure 11 - Beater Gearbox	26-27
Figure 12 - Worm Gearbox	28-29
Figure 13 - Rear Unload Assembly	30-33
Figure 14 - Industrial 2-Way Unload	34-37
Figure 15 - 4th Beater Option	38-39
Figure 16 - Light Harness	40-41
Figure 17 - Unit Harness Routing	42-43
Figure 18 - Control Box	44-45
Figure 19 - Main Wiring Harness	46
Figure 20 - Unit Harness	47
Figure 21 - Extension Hydraulics	48-49
Figure 22 - Optional Air Gate Delay	50-51
Figure 23 - Optional Hydraulic Gate Delay	52-53
Figure 24 - Tie Down	54
Figure 25 - Manifold	55
Figure 26 - Truck Mount Kit	56-57
Parts Notes	58

INSTRUCTIONS FOR ORDERING PARTS

All service parts should be ordered through your authorized H & S dealer. They will be able to give you faster service if you will provide them with the following

1. Model & Serial number is located in the front center of the box.
2. All reference to left or right apply to the Forage Box as viewed from the rear.
3. Parts should not be ordered from illustration only. Please order by complete part number.
4. If your dealer has to order parts - give shipping instructions:

VIA truck - large pieces (please specify local truck lines)

VIA United Parcel Service (include full address)

H&S MFG. CO. INC.	
MARSHFIELD, WIS.	
MOD. NO.	<input type="text"/>
SER. NO.	<input type="text"/>
DESCR.	<input type="text"/>

PLEASE RECORD NUMBERS FOR YOUR UNIT FOR QUICK REFERENCE

ABOUT IMPROVEMENTS

H&S IS CONTINUALLY STRIVING TO IMPROVE IT'S PRODUCTS

We must therefore, reserve the right to make improvements or changes whenever it becomes practical to do so without incurring any obligation to make changes or additions to the equipment previously sold.

FIGURE 1
HOUSING COMPONENTS (SIDES)

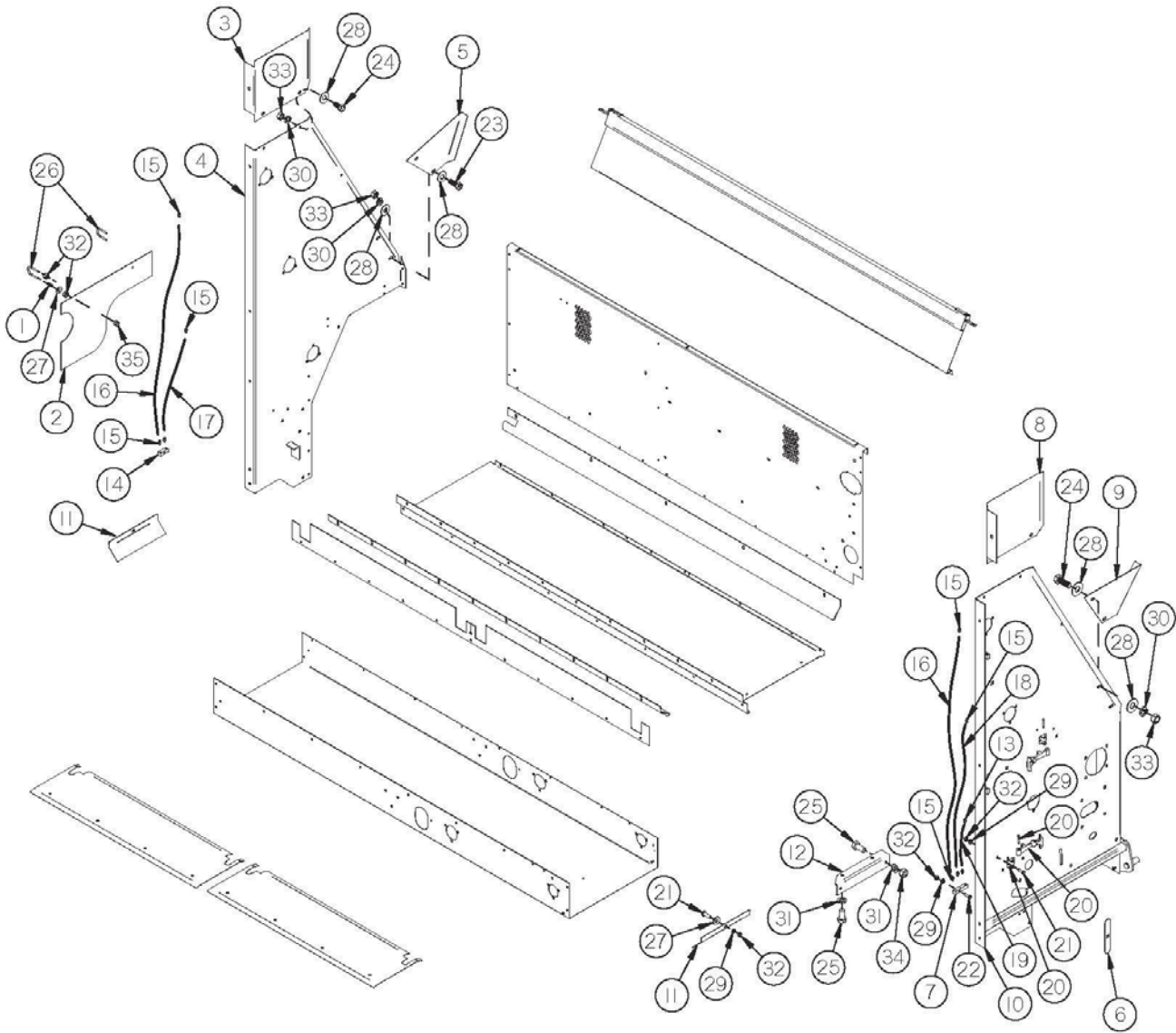

FIGURE 1

HOUSING COMPONENTS (SIDES)

<u>ITEM</u>	<u>QTY</u>	<u>PART #</u>	<u>DESCRIPTION</u>
1	1	S1	SPRING
2	1	S2	POLY SHIELD
3	1	S3	LEFT SIDE PANEL TOP
4	1	SD223	LEFT SIDE PANEL
5	1	S5	LEFT EMERGENCY STOP PANEL
6	1	SD86	SLOT COVER
7	1	SD83	GREASE BLOCK (3-PORT)
*	1	SD146	GREASE BLOCK (4-PORT) 4TH BEATER ONLY
8	1	S9	RIGHT SIDE PANEL TOP
9	1	S11	RIGHT EMERGENCY STOP PANEL
10	1	SD4	RIGHT SIDE PANEL
11	2	S20	APRON SIDE SPACER
12	1	SD99	GEARBOX ANGLE
13	5	SD82	GREASE LINE FITTING 90°
14	1	SD79	GREASE BLOCK
*	1	SD83	GREASE BLOCK (3-PORT) 4TH BEATER ONLY
15	5	S47	GREASE LINE FITTING
16	2	SD80	GREASE LINE (54-1/2")
17	1	SD81	GREASE LINE (40-1/4")
18	1	SD98	GREASE LINE (29")
19	1	SD109	GREASE LINE (14")
20	6	X233	COMPLETE LATCH
21	3	YBHH08100	BOLT, 1/4" X 3/4" GR. 5
22	1	YBHH08010	BOLT, 1/4" X 1" GR. 5
23	4	YBHH12135	BOLT, 3/8" X 3/4" GR. 5
24	4	YBHH12010	BOLT, 3/8" X 1" GR. 5
25	4	YBHH16010	BOLT, 1/2" X 1" GR. 5
26	2	YBPU08005	PIPE U-BOLT, 1/4"-20 X 3/4" PIPE, 1-1/4" ID, 2-1/4" IL, 1-1/4" THREAD
27	3	YWFL08005	WASHER, FLAT, 1/4" USS
28	12	YWFL12005	WASHER, FLAT, 3/8" USS
29	4	YWLO08005	WASHER, LOCK, 1/4"
30	8	YWLO12005	WASHER, LOCK, 3/8"
31	4	YWLO16005	WASHER, LOCK, 1/2"
32	8	YNHX08005	HEX NUT, 1/4"-20
33	8	YNHX12005	HEX NUT, 3/8"-16
34	2	YNHX16005	HEX NUT, 1/2"
35	4	YNNY08005	HEX NUT, NYLON LOCKNUT, 1/4"-20

NOTE: * MEANS NOT SHOWN

FIGURE 2
HOUSING COMPONENTS (FRONT & BOTTOM)

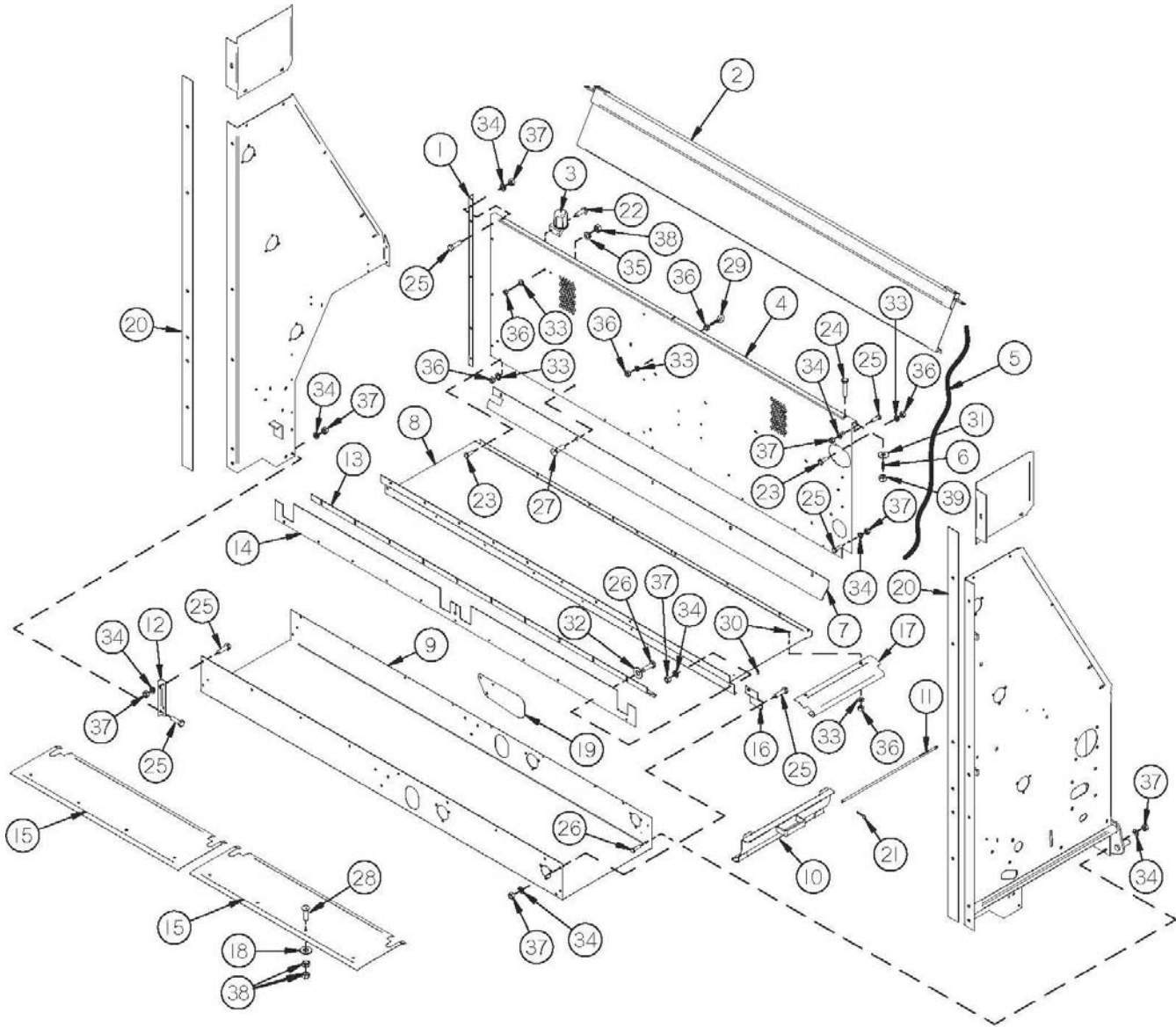

FIGURE 2

HOUSING COMPONENTS (FRONT & BOTTOM)

<u>ITEM</u>	<u>QTY</u>	<u>PART #</u>	<u>DESCRIPTION</u>
1	1	S22	LEFT FRONT ANGLE
2	1	S370	EMERGENCY STOP PANEL
3	1	CHM38	PLUG STORAGE
4	1	SD224	FRONT MAIN PANEL
5	1	S8	EMERGENCY STOP CABLE
*	2	ES14	THIMBLE
*	2	ES15	CABLE CLAMP
6	3	S7	SPRING FOR EMERGENCY STOP
7	1	SD5	CROSS CONVEYOR FRONT HOLD-DOWN
8	1	SD6	CROSS APRON PAN
9	1	SD7	RETURN PAN
10	1	SD8	RETURN PAN END
11	1	SD10	RETURN PAN END ROD
12	1	S19	LEFT RETURN PAN ANGLE
13	1	SD11	CROSS CONVEYOR BACK HOLD-DOWN
14	1	S306	RUBBER SEAL
15	2	PB74	DRIVE SHAFT PANEL
16	1	SD12	TUB END
17	1	SD13	TUB EXTENSION
18	8	S304	TIGHTENER WASHER
19	1	SD221	ACCESS COVER
20	2	SD100	UNIT SPACER
21	1	YPHR02010	HAIR PIN, #21-07
22	2	YBHH08015	BOLT, 1/4" X 1/2" GR. 5
23	10	YBHH08100	BOLT, 1/4" X 3/4" GR. 5
24	3	YBHH08025	BOLT, 1/4" X 1-1/2" GR. 5
25	20	YBHH10105	BOLT, 5/16" X 3/4" GR. 5
26	13	YBHH10010	BOLT, 5/16" X 1" GR. 5
27	5	YBCR12065	CARR. BOLT, 3/8" X 3/4" GR. 5
28	8	YBCR12015	CARR. BOLT, 3/8" X 1-1/2" GR. 5
29	2	YBTE08005	TURNTED EYE BOLT, 1/4" X 1" FULL THREAD
30	2	YSTM08004	SLOTTED TRUSS HEAD ZINC MACHINE SCREW, 1/4"-20 x 3/4"
31	3	YWFL08005	WASHER, FLAT, 1/4" USS
32	11	YWFL10005	WASHER, FLAT, 5/16" USS
33	16	YWLO08005	WASHER, LOCK, 1/4"
34	33	YWLO10005	WASHER, LOCK, 5/16"
35	5	YWLO12005	WASHER, LOCK, 3/8"
36	18	YNHX08005	HEX NUT, 1/4"-20
37	33	YNHX10005	HEX NUT, 5/16"
38	21	YNHX12005	HEX NUT, 3/8"-16
39	3	YNTL08005	HEX NUT, TOP LOCK, 1/4"-20

NOTE: * MEANS NOT SHOWN

FIGURE 3

BEATERS

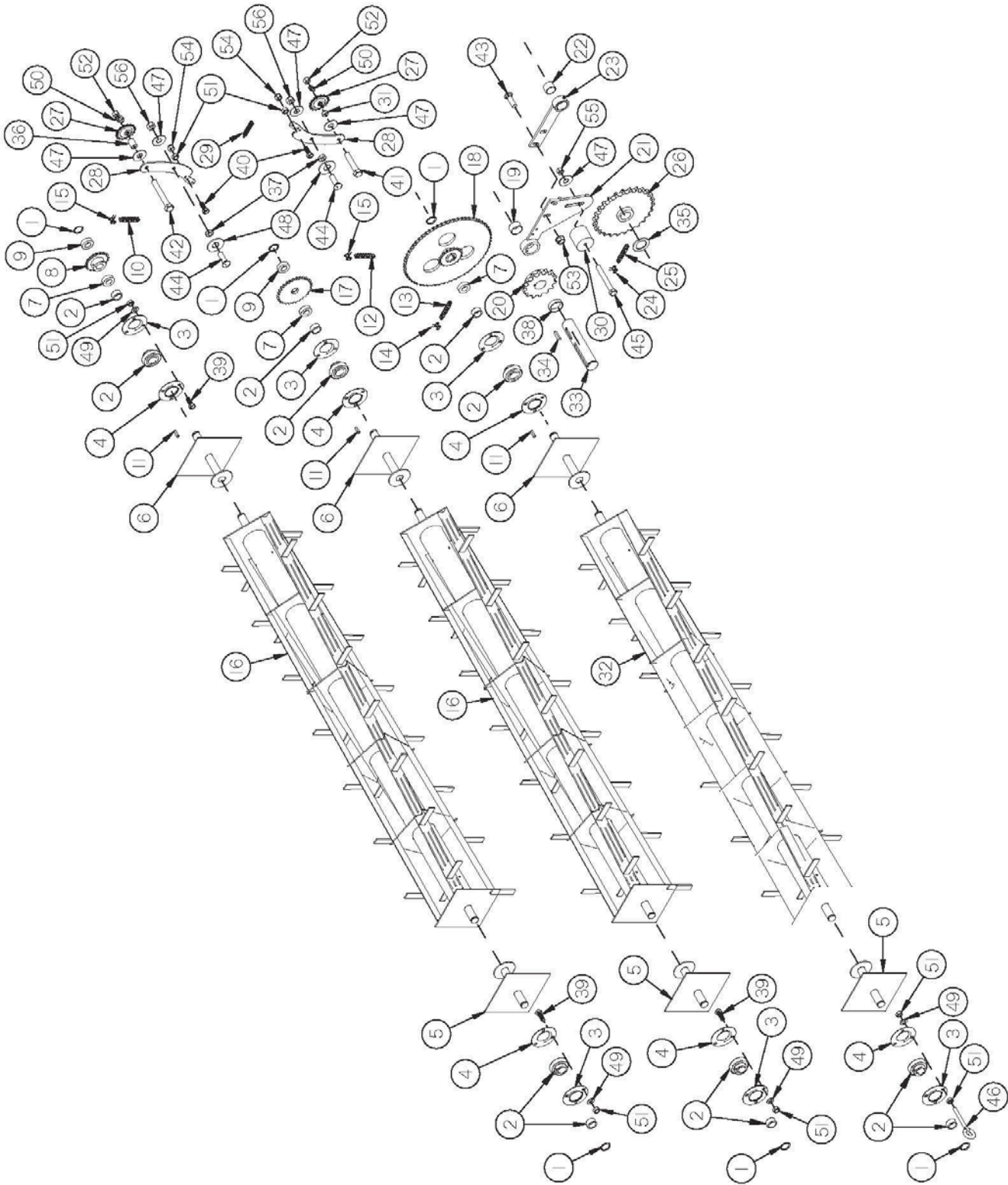

FIGURE 3

BEATERS

<u>ITEM</u>	<u>QTY</u>	<u>PART #</u>	<u>DESCRIPTION</u>
1	6	F73	SNAP RING
2	12	12N122	BEARING W/ LOCK COLLAR ASSY.
3	6	F114	BEARING FLANGE W/ZERK
4	6	F14	BEARING FLANGE
5	3	S23	LEFT BEATER STUB SHAFT
6	3	S24	RIGHT BEATER STUB SHAFT
7	3	S218	3/8" SPACER
8	1	S26	3RD BEATER SPROCKET 20 TOOTH
9	2	S219	1/4" SPACER
10	1	X58	2ND TO 3RD BEATER CHAIN (89 PITCHES X #50)
11	3	G23A	SQUARE KEY, 5/16 X 1-1/4"
12	1	S31	1ST TO 2ND BEATER CHAIN (98 PITCHES X #50)
13	1	SD14	BEATER DRIVE CHAIN (85 PITCHES X #60)
14	1	X61	# 50 CONNECTOR LINK
15	2	D39	# 60 CONNECTOR LINK
16	2	S25	BEATER
17	1	S30	2ND BEATER SPROCKET (30 TO 13 TOOTH)
18	1	SD15	1ST BEATER SPROCKET (20 TO 65 TOOTH)
19	1	SD16	BUSHING (2-1/4" OD X 2" ID X 1.125")
20	1	SD17	WORM SHAFT SPROCKET (100-B-14)
21	1	SD18	WORM SHAFT BRACE
22	1	S44	BUSHING (2" OD X 1-3/4" ID X 1.125")
23	1	SD19	DRIVE SHAFT BRACE
24	1	33SV77	# 100 CONNECTOR LINK
25	1	SD20	DRIVE CHAIN (#100 X 47 PITCH)
26	1	SD23	CLUTCH ASSEMBLY SPROCKET
27	2	K101	SPROCKET 17 TOOTH
28	2	SD77	TIGHTENER BAR

FIGURE 3

BEATERS

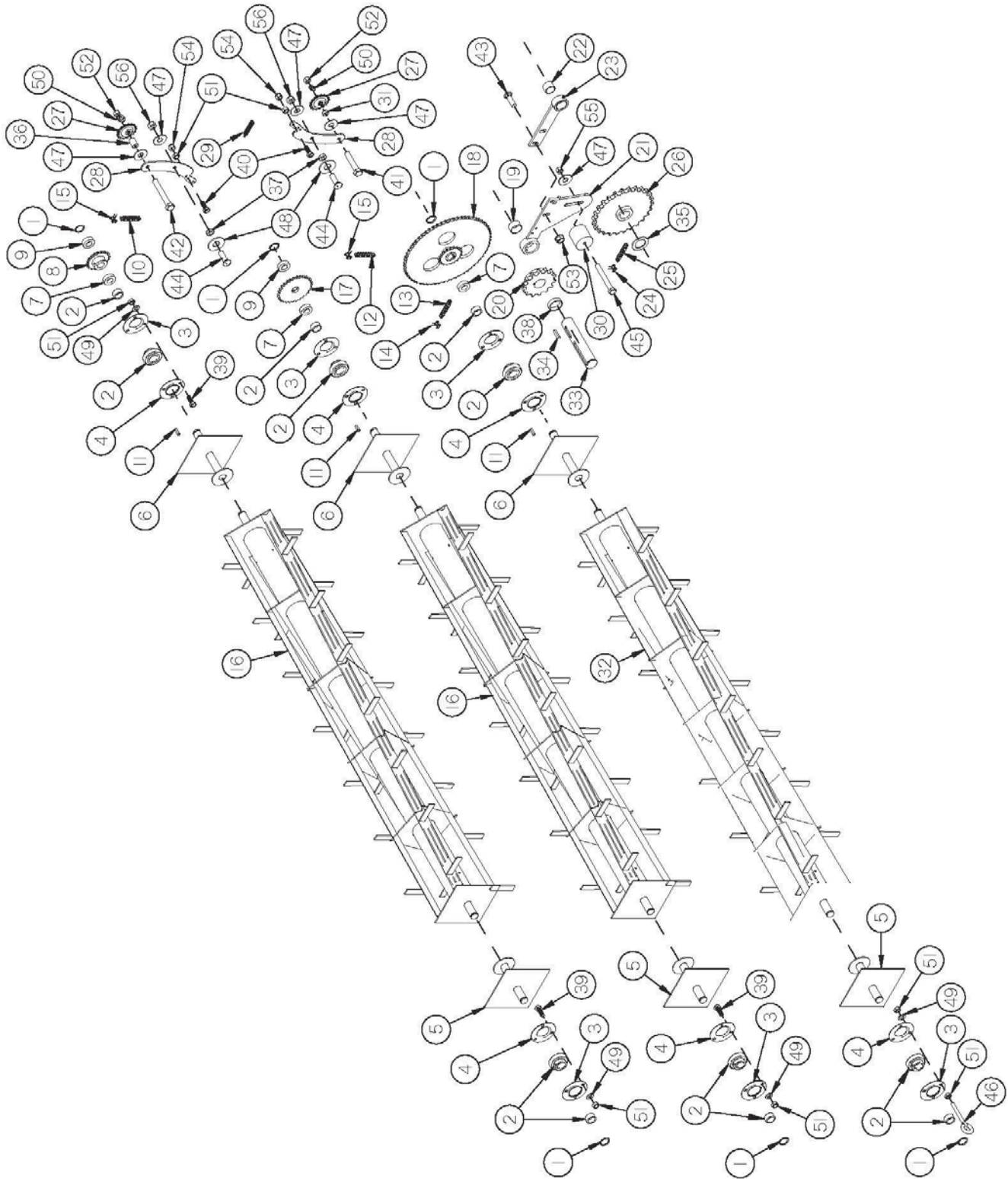

FIGURE 3

BEATERS

<u>ITEM</u>	<u>QTY</u>	<u>PART#</u>	<u>DESCRIPTION</u>
29	1	R27	SPRING
30	1	SD84	POLY TIGHTENER
31	1	SD88	TENSIONER SPACER
32	1	SD107	1ST BEATER (5 CROSSES)
33	1	SD89	OUTPUT SHAFT (A110)
34	1	G139	3/8" X 1-1/2" SQUARE KEY HARDENED
35	1	S36	DRIVE SHAFT SPACER
36	1	SD212	TENSIONER SPACER
37	2	SD177	SPACER
38	1	SDPI07	OUTPUT SHAFT SPACER
39	17	YBHH12010	BOLT, 3/8" X 1" GR. 5
40	2	YBHH12035	BOLT, 3/8" X 1-1/4" GR. 5
41	1	YBHH16080	BOLT, 1/2" X 2-1/2" GR. 5
42	1	YBHH16115	BOLT, 1/2" X 3-1/2" GR. 5
43	2	YBCR16015	CARR. BOLT, 1/2" X 1-1/4" GR. 5
44	2	YBCR16010	CARR. BOLT, 1/2" X 1-1/2" GR. 5
45	1	YBCR16045	CARR. BOLT, 1/2" X 4" GR. 5
46	1	YBTE12015	TURNUED EYE BOLT, 3/8" X 2-1/2"
47	5	YWFL16005	WASHER, FLAT, 1/2" USS
48	2	YWFL24005	WASHER, FLAT, 3/4" USS
49	18	YWLO12005	WASHER, LOCK, 3/8"
50	2	YWLO16005	WASHER, LOCK, 1/2"
51	21	YNHX12005	HEX NUT, 3/8"-16
52	2	YNHX16005	HEX NUT, 1/2"
53	2	YNFG16005	HEX NUT, FLANGED-LOCK, 1/2"-13
54	2	YNNY12005	HEX NUT, NYLON LOCKNUT, 3/8"
55	1	YNRL16005	HEX NUT, REVERSIBLE-SIDE LOCK, 1/2"-13
56	2	YNNTL16005	HEX NUT, TOP LOCK, 1/2"-13

FIGURE 4

APRON DRIVE

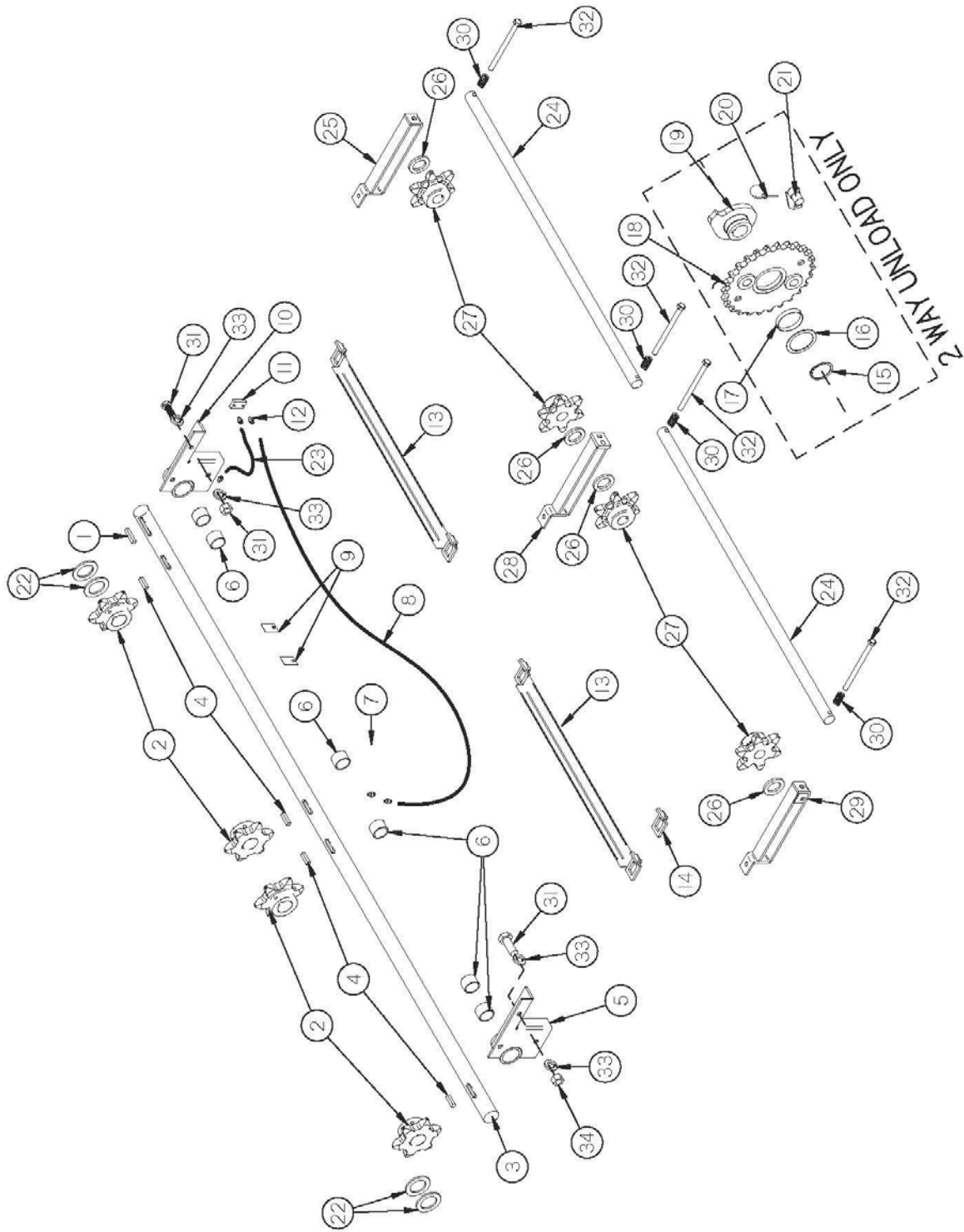

FIGURE 4

APRON DRIVE

<u>ITEM</u>	<u>QTY</u>	<u>PART #</u>	<u>DESCRIPTION</u>
1	1	S38	KEY, 3/8" X 2-3/8" SQUARE
2	4	SD213	APRON DRIVE SHAFT SPROCKET
3	1	SD22	DRIVE SHAFT
4	4	56N174	3/8" X 2" SQUARE KEY W/ROUND ENDS (HARDENED)
5	1	S51	LEFT DRIVE SHAFT BRACKET
6	6	S50	DRIVE SHAFT BUSHING (2" OD X 1-3/4" ID X 1.125")
7	1	S53	CENTER BEARING BRACKET
8	1	S49	GREASE LINE (LONG)
9	2	S67	GREASE LINE CLIP
10	1	S52	RIGHT DRIVE SHAFT BRACKET
11	1	S46	GREASE LINE BRACKET
12	4	S47	GREASE LINE FITTING
13	1	S233	667H PINTLE SLAT/ATTACHMENT LINKS
*	1	S54	T-ROD SLAT W/ATTACHMENT LINKS
14	1	11S50	667H PINTLE ATTACHMENT LINK (R OR L)
*	1	S55	T-ROD ATTACHMENT LINK (R OR L)

COMPLETE APRON FOR FRONT UNLOAD

*	1	S57	T-ROD APRON 14'
*	1	S230	667H PINTLE APRON 14'
*	1	S58	T-ROD APRON 16'
*	1	S231	667H PINTLE APRON 16'
*	1	S59	T-ROD APRON 18'
*	1	S32	667H PINTLE APRON 18'
*	1	S422	T-ROD APRON 20'
*	1	S432	667H PINTLE APRON 20'

NOTE: * MEANS NOT SHOWN

FIGURE 4 APRON DRIVE

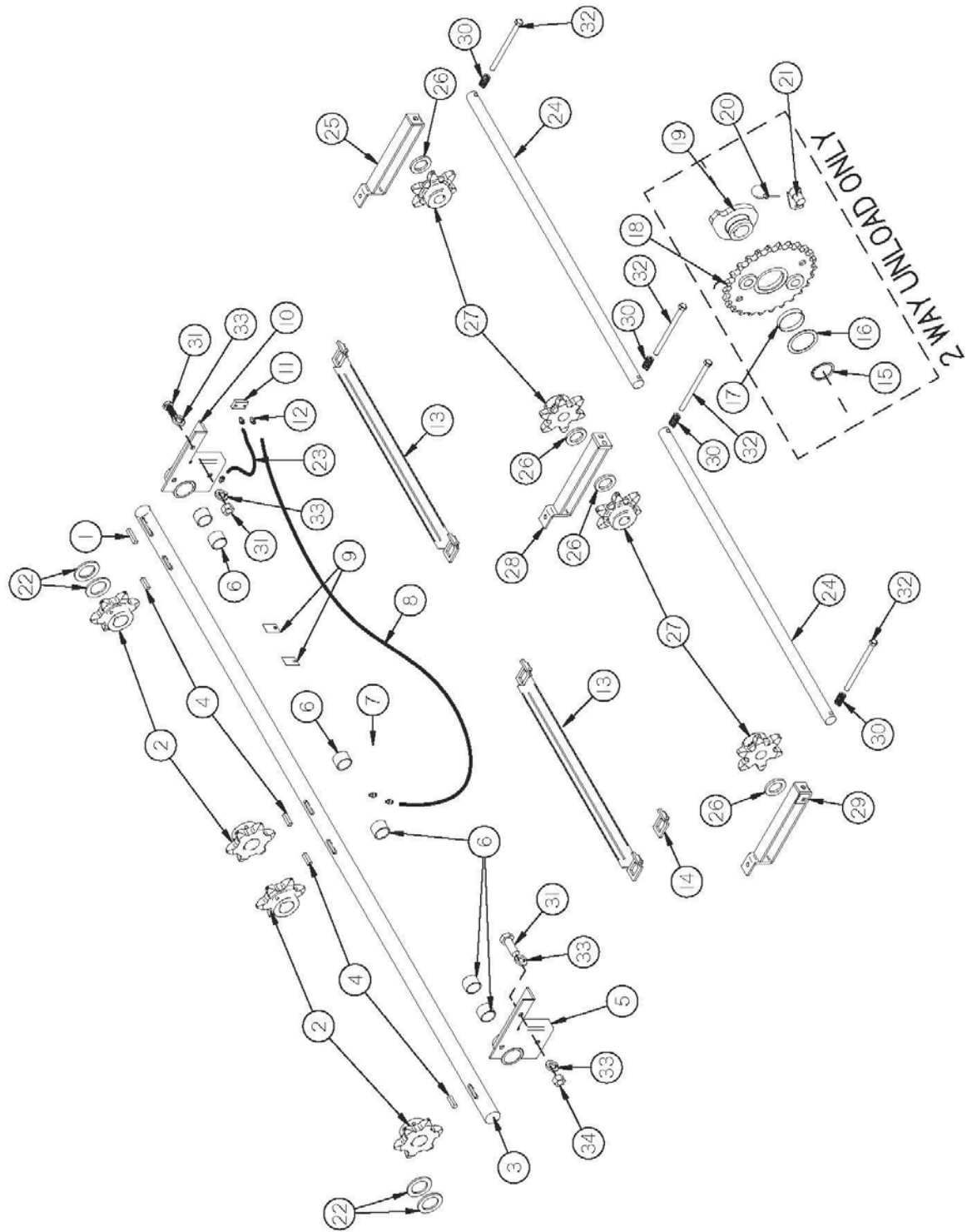

FIGURE 4

APRON DRIVE

<u>ITEM</u>	<u>QTY</u>	<u>PART#</u>	<u>DESCRIPTION</u>
15	1	SD202	SNAP RING (5100-300)
16	1	SD203	CLUTCH SPROCKET WASHER
17	1	SD204	BRONZE BUSHING (3-1/4"OD X 3"ID X 1/2")
18	1	SD23	DRIVE SHAFT SPROCKET (100-A-26)
19	1	SD205	FRONT CLUTCH DOG
20	1	PB190	LYNCH PIN
21	1	PB191	CLUTCH DOG
22	4	S36	DRIVE SHAFT SPACER
23	1	S48	GREASE LINE
24	1	S63	IDLER SHAFT
25	1	S65	RIGHT HAND REAR IDLER BRACKET
26	4	S61	IDLER SPACER
27	4	S60	IDLER SPROCKET
28	1	S64	CENTER IDLER BRACKET
29	1	S62	LEFT HAND REAR IDLER BRACKET
30	4	WM210	SPRING - RED
31	6	YBHH16045	BOLT, 1/2" X 1-1/4" GR. 5
32	4	YBHH16190	BOLT, 1/2" X 9-1/2" GR. 5
33	12	YWLO16005	WASHER, LOCK, 1/2"
34	6	YNHX16005	HEX NUT, 1/2"

COMPLETE APRON FOR FRONT & REAR UNLOAD

*	1	S324	667H PINTLE APRON 16'
*	1	S325	667H PINTLE APRON 18'
*	1	S326	667H PINTLE APRON 20'

NOTE: * MEANS NOT SHOWN

FIGURE 5
CROSS APRON DRIVE

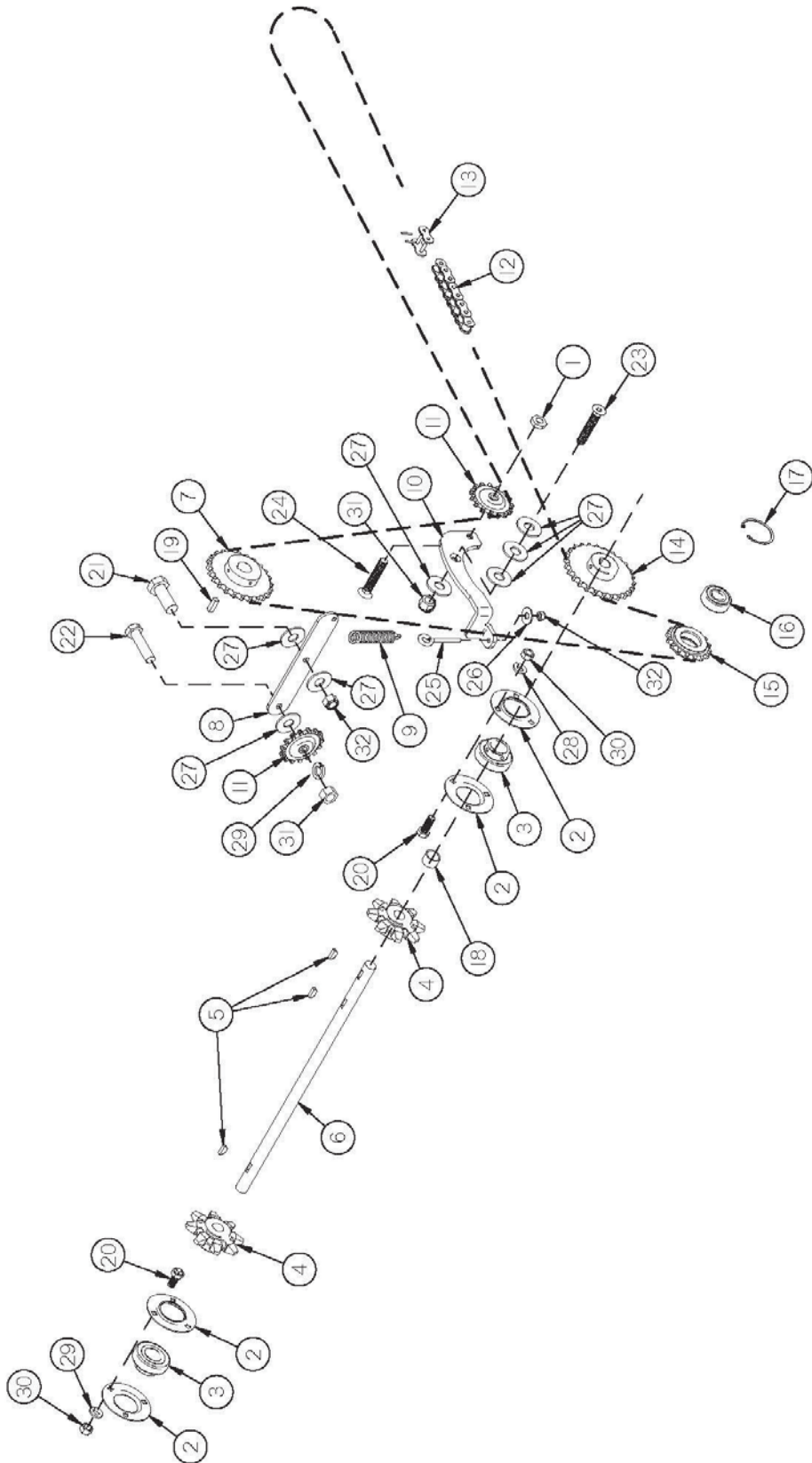

FIGURE 5

CROSS APRON DRIVE

<u>ITEM</u>	<u>QTY</u>	<u>PART #</u>	<u>DESCRIPTION</u>
1	1	YNTJ16005	HEX NUT, TOP LOCK, JAM 1/2'-13
2	4	4C7	BEARING FLANGE
3	2	4C8	BEARING WITH LOCK COLLAR
4	2	L10R24	8 TOOTH SPROCKET
5	3	5B10	1/4" X 1" WOODRUFF KEY
6	1	SD24	CROSS APRON DRIVE SHAFT
7	1	SD25	SPROCKET (60-B-24)
8	1	SD87	PRIMARY TIGHTENER BAR
9	1	ST36	SPRING
10	1	SD91	CHAIN TIGHTENER PRIMARY
11	2	12N42	15 TOOTH IDLER SPROCKET
12	1	SD222	# 60 CHAIN X 155 PITCH
13	1	D39	# 60 CONNECTOR LINK
14	1	SD225	CROSS APRON DRIVE SPROCKET (60-B-30)
15	1	SD28	IDLER SPROCKET (60-C-16)
16	1	SD263	BEARING
17	1	K92	SNAP RING
18	1	SD210	APRON SPROCKET SPACER
19	6	YBHH12135	BOLT, 3/8" X 3/4" GR. 5
20	1	YBHH16045	BOLT, 1/2" X 1-1/4" GR. 5
21	1	YBHH16065	BOLT, 1/2" X 2" GR. 5
22	1	YSFS16025	FLAT HEAD SOCKET CAP SCREW, 1/2" X 2"
23	1	YSFS16035	FLAT HEAD SOCKET CAP SCREW, 1/2" X 2-1/4"
24	1	YBTE10015	TURNUED EYE BOLT, 5/16" X 2-1/2"
25	1	YWFL10005	WASHER, FLAT, 5/16" USS
26	7	S247	EXTENSION WASHER
27	6	YWLO12005	WASHER, LOCK, 3/8"
28	1	YWLO16005	WASHER, LOCK, 1/2"
29	6	YNHX12005	HEX NUT, 3/8"-16
30	1	YNHX16005	HEX NUT, 1/2"
31	6	YNNY16005	HEX NUT, NYLON LOCKNUT, 1/2"
32	1	YNTL10005	HEX NUT, TOP LOCK, 5/16"-18

FIGURE 6

EXTENSION

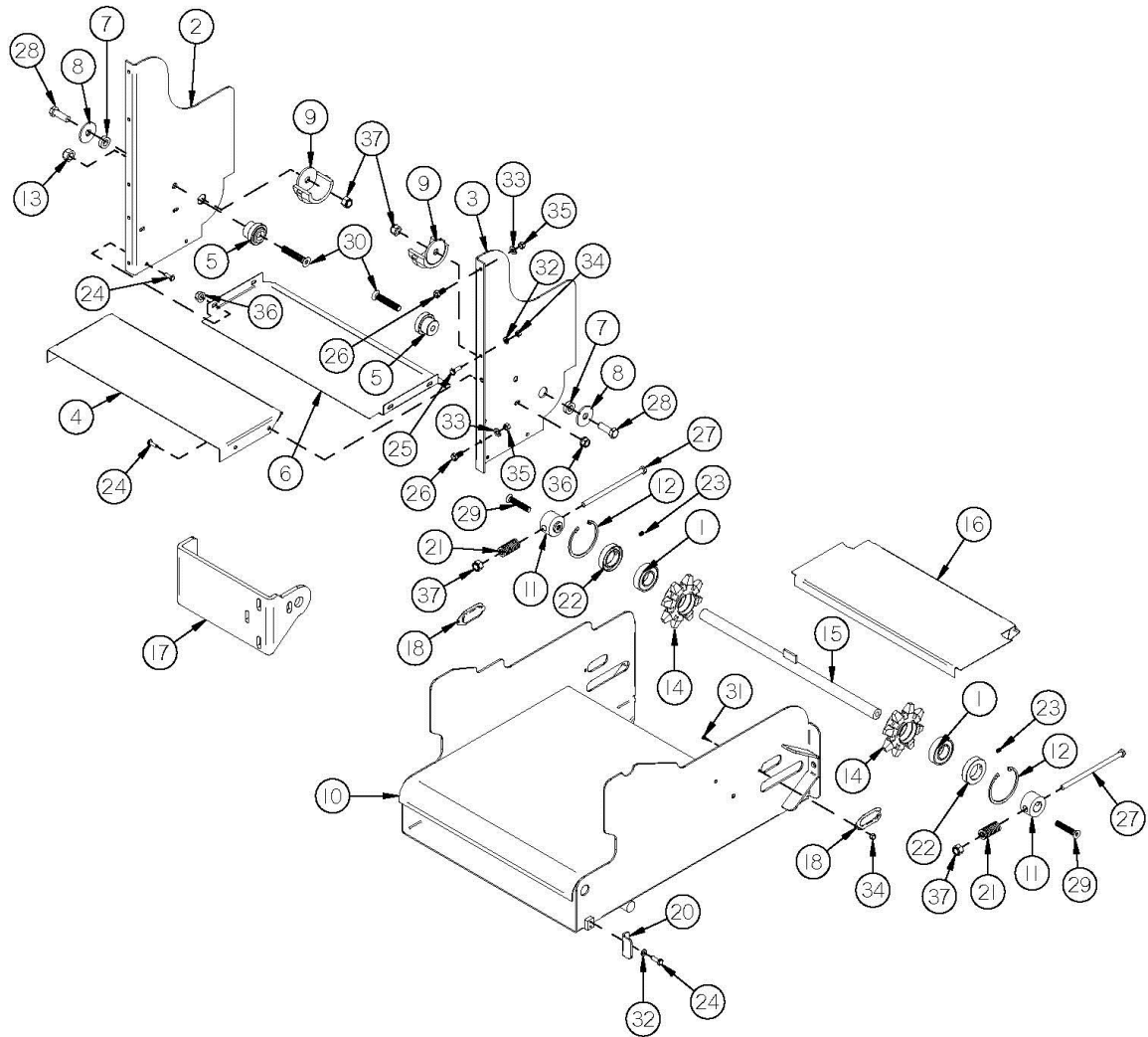

FIGURE 6

EXTENSION

<u>ITEM</u>	<u>QTY</u>	<u>PART #</u>	<u>DESCRIPTION</u>
1	2	SD263	BEARING
2	1	SD172	EXTENSION BACK PANEL
3	1	SD173	EXTENSION FRONT PANEL
4	1	SD174	PAN EXTENSION
5	2	SD175	CHAIN ROLLER HOLD-DOWN
6	1	SD176	RETURN PAN EXTENSION
7	2	SD177	SHELL SPACER
8	2	S247	EXTENSION WASHER
9	2	S245	CHAIN SLIDE
10	1	SD261	EXTENSION SHELL LONG
11	2	SD313	TIGHTENER
12	2	SD262	SNAP RING (Arcon IN206)
13	2	YNTL16005	HEX NUT, TOP LOCK, 1/2" - 13
14	2	SD180	8 TOOTH SPROCKET
15	1	SD314	APRON IDLER SHAFT
16	1	SD182	CHAIN SLIDE
17	1	SD248	CYLINDER MOUNT TOP
18	2	SD186	COVER
19	1	SD250	LIMIT SWITCH MOUNT
20	1	SD249	LIMIT SWITCH PAD
21	2	WM210	SPRING - RED
*	1	S89	CROSS CONVEYOR (123 LINKS)
*	1	SD306	CROSS CONVEYOR (31 LINKS)
*	1	SD311	CROSS CONVEYOR (S89 W/ SD306)
*	1	K121	CONNECTOR LINK
22	2	SD312	BEARING SHIELD
23	2	YSKP08010	SET SCREW, SOCKET, KNURLED CUP PT, 1/4"-20 X 1/2"
24	8	YBHH08015	BOLT, 1/4" X 1/2" GR. 5
25	5	YBHH08100	BOLT, 1/4" X 3/4" GR. 5
26	4	YBHH10105	BOLT, 5/16" X 3/4" GR. 5
27	2	YBHH16180	BOLT, 1/2" X 7" GR. 5
28	2	YBHH16030	BOLT, 1/2" X 1-1/2" GR. 5
29	2	YSFS16015	FLAT HEAD SOCKET CAP SCREW, 1/2" X 1-1/4"
30	2	YSFS16030	FLAT HEAD SOCKET CAP SCREW, 1/2" X 2-1/2"
31	2	YSTM08004	SLOTTED TRUSS HEAD ZINC MACHINE SCREW, 1/4"-20 x 3/4"
32	5	YWLO08005	WASHER, LOCK, 1/4"
33	4	YWLO10005	WASHER, LOCK, 5/16"
34	7	YNHX08005	HEX NUT, 1/4"-20
35	4	YNHX10005	HEX NUT, 5/16"
36	8	YNFG08005	HEX NUT, FLANGED-LOCK, 1/4"
37	6	YNNY16005	HEX NUT, NYLON LOCKNUT, 1/2"

NOTE: * MEANS NOT SHOWN

FIGURE 7

HYDRAULIC DRIVE (CAB CONTROL)

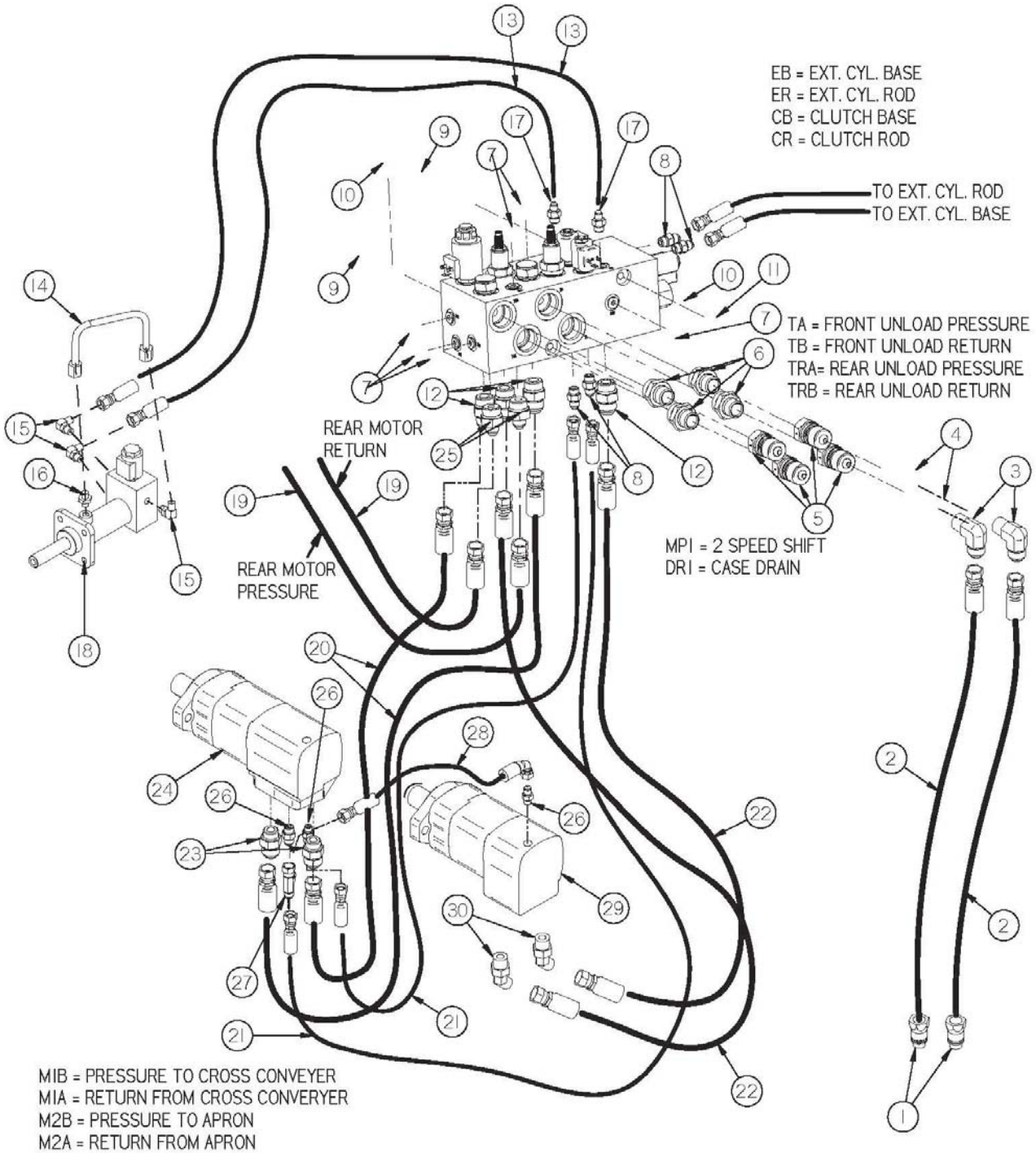

FIGURE 7

HYDRAULIC DRIVE (CAB CONTROL)

<u>ITEM</u>	<u>QTY</u>	<u>PART #</u>	<u>DESCRIPTION</u>
1	2	DWM205	QUICK COUPLER MALE 1/2"
2	2	SD264	HYDRAULIC HOSE 3/4" x 151" (101HY-8-12, 106HY-12-12)
3	2	SD265	MALE ELBOW (12 CTX)
4	2	SD266	QUICK COUPLER FEMALE 3/4"
5	4	SD267	QUICK COUPLER MALE 3/4" (ONLY 2 USED ON FRONT UNLOAD)
6	4	SD319	MALE PIPE ADAPTER (16-3/4 F5OF) (ONLY 2 USED ON FRONT UNLOAD)
*	2	SD269	PLUG - 16HP50N (USED ON FRONT UNLOAD ONLY)
7	6	SD270	HOLLOW HEX PLUG (6HP50N)
8	4	CHM257	STRAIGHT THREAD CONNECTOR (6 F5OX)
9	2	YBHH12215	BOLT, 3/8" X 5-1/2" GR. 5
10	2	YWLO12005	WASHER, LOCK, 3/8"
11	2	YNHX12005	HEX NUT, 3/8"-16
12	4	SD273	STRAIGHT THREAD CONNECTOR (12 F5OX) (ONLY 2 USED ON FRONT UNLOAD)
13	2	SD275	HYDRAULIC HOSE 1/4" x 32" (106HY-4-4, 106HY-4-4)
14	1	SD276	STEEL LINE
15	3	CHM165	MALE STRAIGHT THREAD (4 C50X)
16	1	58094	FITTING, STRAIGHT, 4 F50X-S
17	2	SD279	STRAIGHT THREAD CONNECTOR (4-6 F5OX)
18	1	SD280	SHIFTER CYLINDER COMPLETE
19	2	SD281	HYDRAULIC HOSE 1/2" X 49" (101HY-8-8, 106HY-8-8) (2-WAY UNLOAD ONLY)
20	2	SD282	HYDRAULIC HOSE 3/4" X 45-1/2" (106HY-12-12, 106HY-10-12)
21	2	SD283	HYDRAULIC HOSE 3/8" X 45" (106HY-6-6, 106HY-6-6)
22	2	SD284	HYDRAULIC HOSE 3/4" X 30" (106HY-12-12 106HY-10-12)
23	2	GM57	STRAIGHT THREAD CONNECTOR (10 F5OX)
24	1	SD285	HYDRAULIC MOTOR (104-2009-2013)
25	2	SD315	STRAIGHT THREAD CONNECTOR (8-12 F5OX) (2-WAY UNLOAD ONLY)
26	2	SD274	PLUG - 12HP50N (USED ON FRONT UNLOAD ONLY)
27	3	CHM300	STRAIGHT THREAD CONNECTOR (6-4 F5OX)
*	1	CHM242	SWIVEL NUT RUN TEE (6 R6X)
28	1	SD286	HYDRAULIC HOSE 3/8" X 10 (139HY-6-6, 106HY-6-6)
29	1	16SV150	HYDRAULIC MOTOR (104-1027)
30	2	SD320	45° STRAIGHT THREAD ELBOW (10 V50X)

NOTE: * MEANS NOT SHOWN

FIGURE 8
BEATER CLUTCH

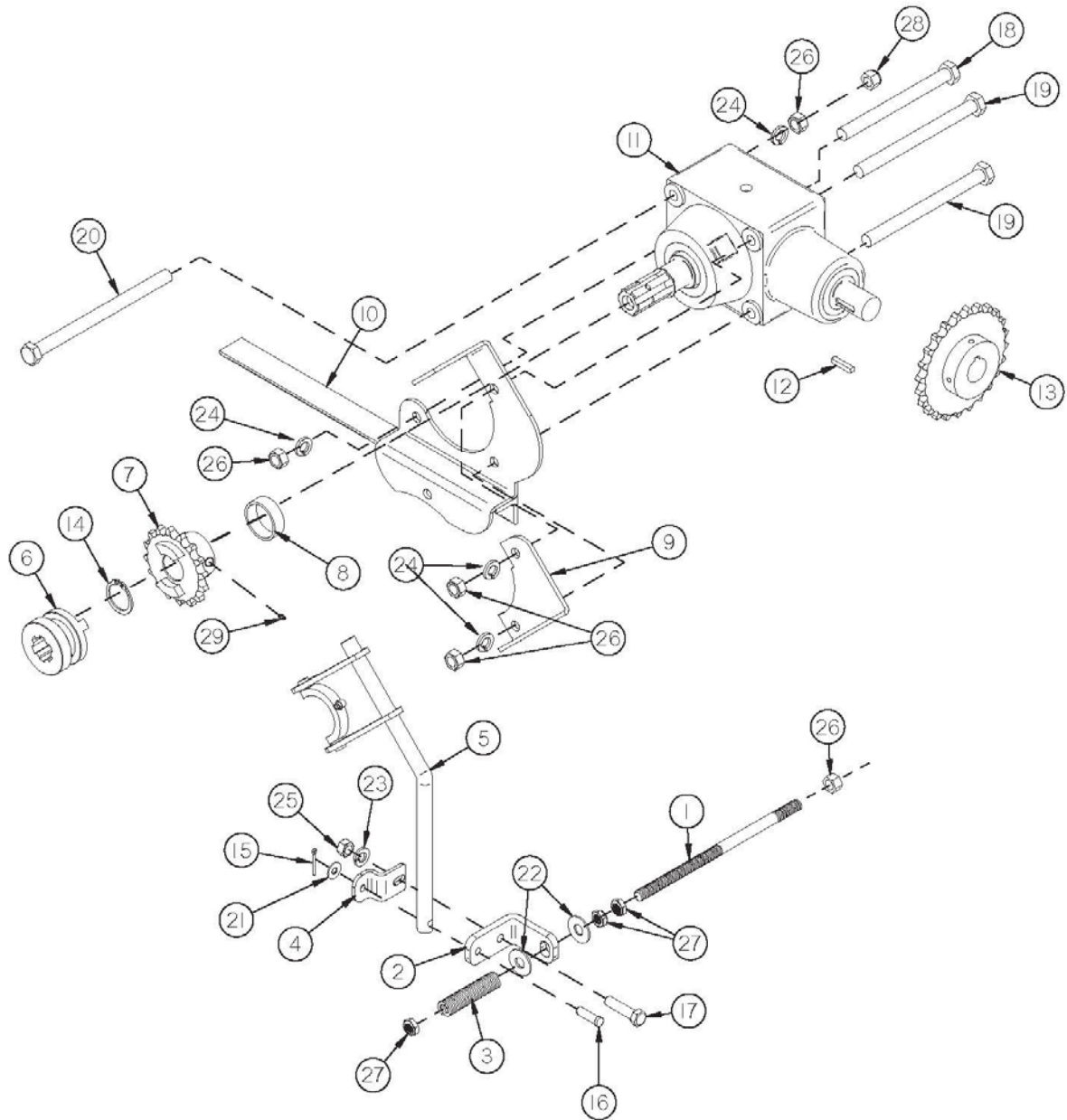

FIGURE 8

BEATER CLUTCH

<u>ITEM</u>	<u>QTY</u>	<u>PART #</u>	<u>DESCRIPTION</u>
1	1	SD235	SHIFTING ROD
2	1	SD94	SHIFTER FORK END
3	1	S111	SPRING
4	1	SD152	SHIFTER FORK END OFFSET
5	1	SD41	SHIFTER FORK
6	1	SD45	CLUTCH (SLIDING)
7	1	SDAS26	BEATER CLUTCH SPROCKET
8	1	SDMS27	BUSHING (1-5/8"OD X 1-3/8"ID X 1-5/8")
9	1	SD40	SHIFTER BRACKET
10	1	SD42	CLUTCH PIVOT
11	1	SD237	BEATER GEARBOX COMPLETE
12	1	SD291	KEY, 5/16" X 1-1/4" W/ ROUND ENDS
13	1	SD25	SPROCKET (60-B-24)
14	1	SD85	RETAINING RING (5100-137)
15	1	YPCT04005	COTTER PIN, 1/8" X 1"
16	1	YPCV10005	CLEVIS PIN, 5/16" X 1-3/4"
17	1	YBHH12025	BOLT, 3/8" X 1-1/2" GR. 5
18	1	YBHH16160	BOLT, 1/2" X 5-1/2" GR. 5
19	1	YBHH16165	BOLT, 1/2" X 6" GR. 5
20	2	YBHH16180	BOLT, 1/2" X 7" GR. 5
21	1	YWFL10005	WASHER, FLAT, 5/16" USS
22	1	YWFL16005	WASHER, FLAT, 1/2" USS
23	2	YWLO12005	WASHER, LOCK, 3/8"
24	1	YWLO16005	WASHER, LOCK, 1/2"
25	4	YNHX12005	HEX NUT, 3/8"-16
26	1	YNHX16005	HEX NUT, 1/2"
27	4	YNJM16005	HEX NUT, JAM, 1/2"-13
28	2	YNNY16005	HEX NUT, NYLON LOCKNUT, 1/2"
29	2	MS26	1/4" - 28, STRAIGHT STANDARD SHORT

FIGURE 9
MOTOR MOUNT

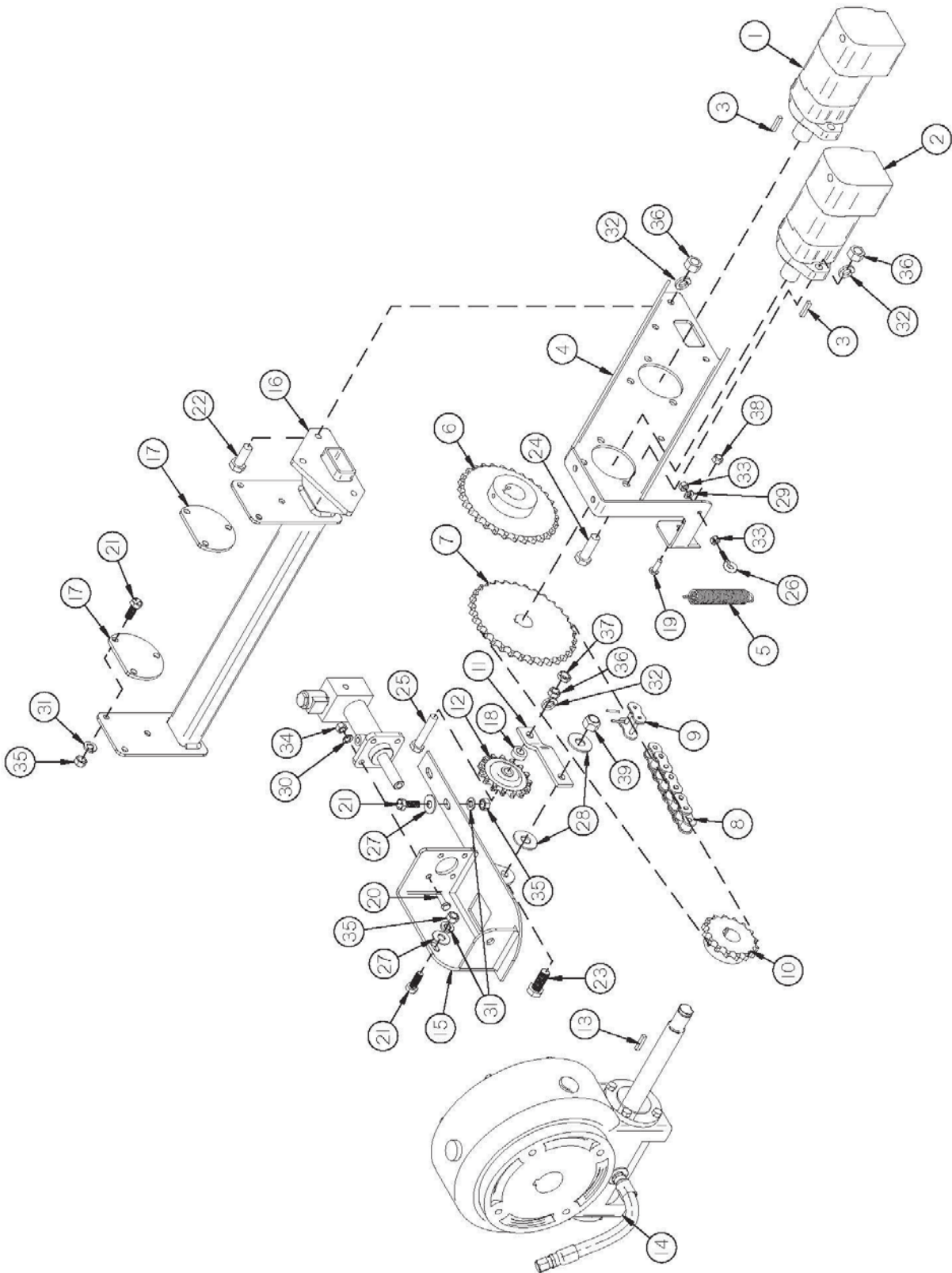

FIGURE 9

MOTOR MOUNT

<u>ITEM</u>	<u>QTY</u>	<u>PART #</u>	<u>DESCRIPTION</u>
1	1	16SV150	HYDRAULIC MOTOR (104-1027-006)
2	1	SD285	HYDRAULIC MOTOR (104-2013-001)
3	2	SD289	KEY, 5/16" X 1-1/4" W/ SQ. ENDS, HARDENED
4	1	SD227	MOTOR MOUNT BRACKET
5	1	R27	SPRING
6	1	SD238	SPROCKET (60-B-30)
7	1	37N71	SPROCKET (60-B-20)
8	1	SD228	CHAIN (60 x 55 PITCHES) COMPLETE
9	1	D39	#60 CONNECTOR LINK
10	1	SD290	SPROCKET (60-B 16)
11	1	12N42	15 TOOTH IDLER SPROCKET
12	1	SD229	WORM CHAIN TIGHTENER
13	1	PB218	KEY (1/4" X 1-1/2")
14	1	SD230	WORM GEARBOX
15	1	SD231	SHIFTER CYLINDER MOUNT
16	1	SD233	TUBING MOUNT
17	2	SD234	CLUSTER CAP
18	1	R65	SHIELD SPACER
19	1	YBHH08100	BOLT, 1/4" X 3/4" GR. 5
20	4	YBHH10010	BOLT, 5/16" X 1" GR. 5
21	9	YBHH12010	BOLT, 3/8" X 1" GR. 5
22	2	YBHH16045	BOLT, 1/2" X 1-1/4" GR. 5
23	1	YBHH16030	BOLT, 1/2" X 1-1/2" GR. 5
24	4	YBHH16055	BOLT, 1/2" X 1-3/4" GR. 5
25	1	YBHH16105	BOLT, 1/2" X 3" GR. 5
26	1	YBTE08005	TURNUED EYE BOLT, 1/4" X 1" FULL THREAD
27	3	YWFL12005	WASHER, FLAT, 3/8" USS
28	2	YWFL16005	WASHER, FLAT, 1/2" USS
29	1	YWLO08005	WASHER, LOCK, 1/4"
30	4	YWLO10005	WASHER, LOCK, 5/16"
31	9	YWLO12005	WASHER, LOCK, 3/8"
32	8	YWLO16005	WASHER, LOCK, 1/2"
33	2	YNHX08005	HEX NUT, 1/4"-20
34	4	YNHX10005	HEX NUT, 5/16"
35	9	YNHX12005	HEX NUT, 3/8"-16
36	8	YNHX16005	HEX NUT, 1/2"
37	1	YNNJ16005	HEX NUT, NYLON JAM NUT, 1/2"
38	1	YNTL08005	HEX NUT, TOP LOCK, 1/4"-20
39	1	YNTL16005	HEX NUT, TOP LOCK, 1/2"-13

FIGURE 10

SHIELDS

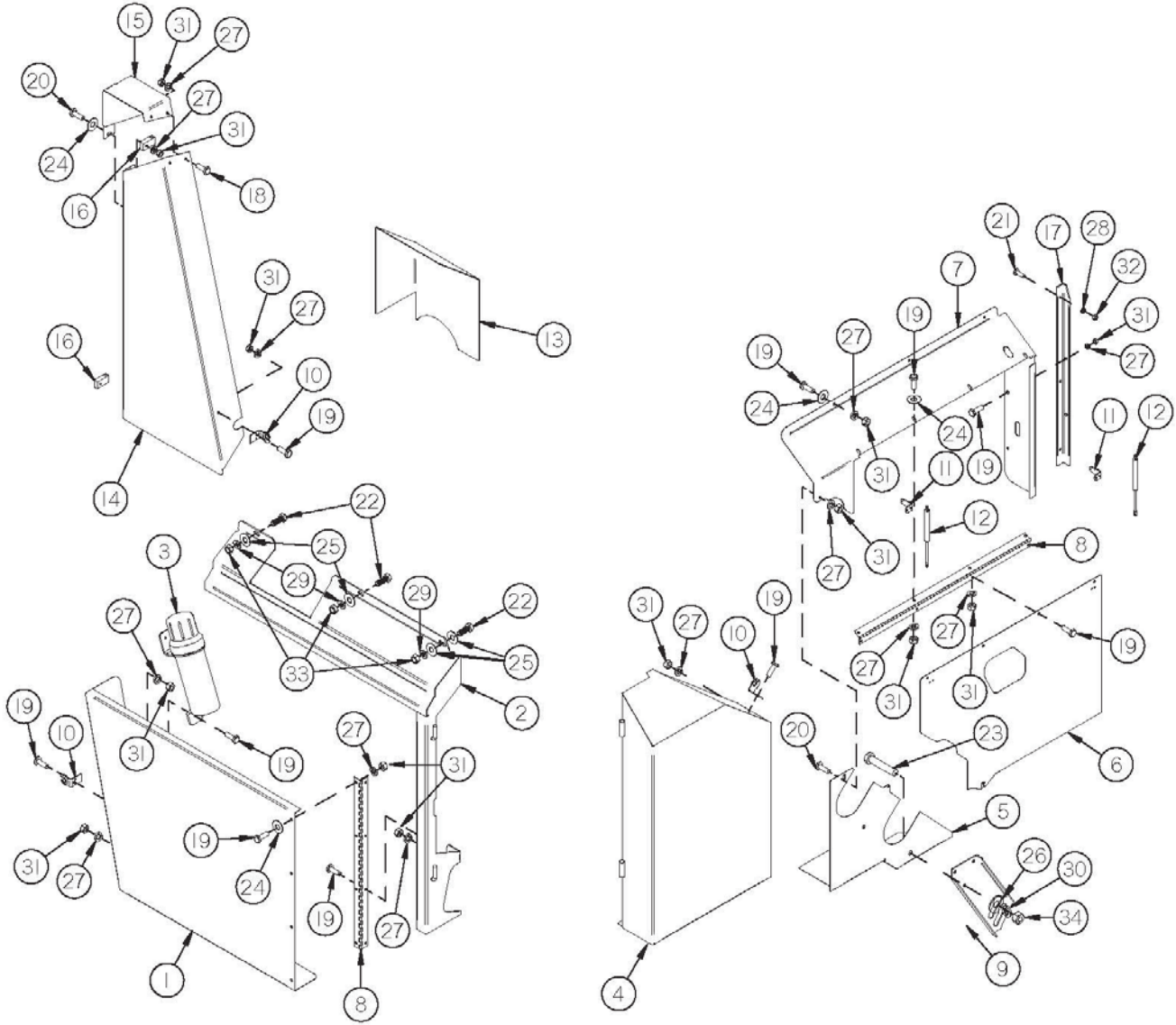

FIGURE 10

SHIELDS

<u>ITEM</u>	<u>QTY</u>	<u>PART #</u>	<u>DESCRIPTION</u>
1	1	SD106	MAIN SIDE SHIELD LOWER
2	1	SD161	HINGE BAR
3	1	S522	MANUAL HOLDER
4	1	SD239	FRONT CORNER SHIELD
5	1	SD240	FRONT SHIELD LOWER
6	1	SD241	FRONT SHIELD FACE
7	1	SD242	VALVE SHIELD
8	2	SD165	CONTINUOUS HINGE
9	1	SD244	QUICK COUPLER HOLDER
10	3	X233	COMPLETE LATCH
11	2	SD189	STRUT TOP MOUNT
12	2	SD190	GAS STRUT
13	1	SD111	GEARBOX SHIELD
14	1	SD167	SIDE SHIELD TOP
15	1	SD168	SHIELD TOP
16	2	SD169	LIFT-OFF HINGE
17	1	SD151	FRONT PANEL BRACE
18	2	YBHH08015	BOLT, 1/4" X 1/2" GR. 5
19	27	YBHH08100	BOLT, 1/4" X 3/4" GR. 5
20	3	YBHH08010	BOLT, 1/4" X 1" GR. 5
21	3	YBHH10105	BOLT, 5/16" X 3/4" GR. 5
22	3	YBHH12010	BOLT, 3/8" X 1" GR. 5
23	2	YBHH16080	BOLT, 1/2" X 2-1/2" GR. 5
24	13	YWFL08005	WASHER, FLAT, 1/4" USS
25	4	YWFL12005	WASHER, FLAT, 3/8" USS
26	2	YWFL16005	WASHER, FLAT, 1/2" USS
27	32	YWLO08005	WASHER, LOCK, 1/4"
28	3	YWLO10005	WASHER, LOCK, 5/16"
29	3	YWLO12005	WASHER, LOCK, 3/8"
30	2	YWLO16005	WASHER, LOCK, 1/2"
31	32	YNHX08005	HEX NUT, 1/4"-20
32	3	YNHX10005	HEX NUT, 5/16"
33	3	YNHX12005	HEX NUT, 3/8"-16
34	2	YNHX16005	HEX NUT, 1/2"

FIGURE 11
BEATER GEARBOX

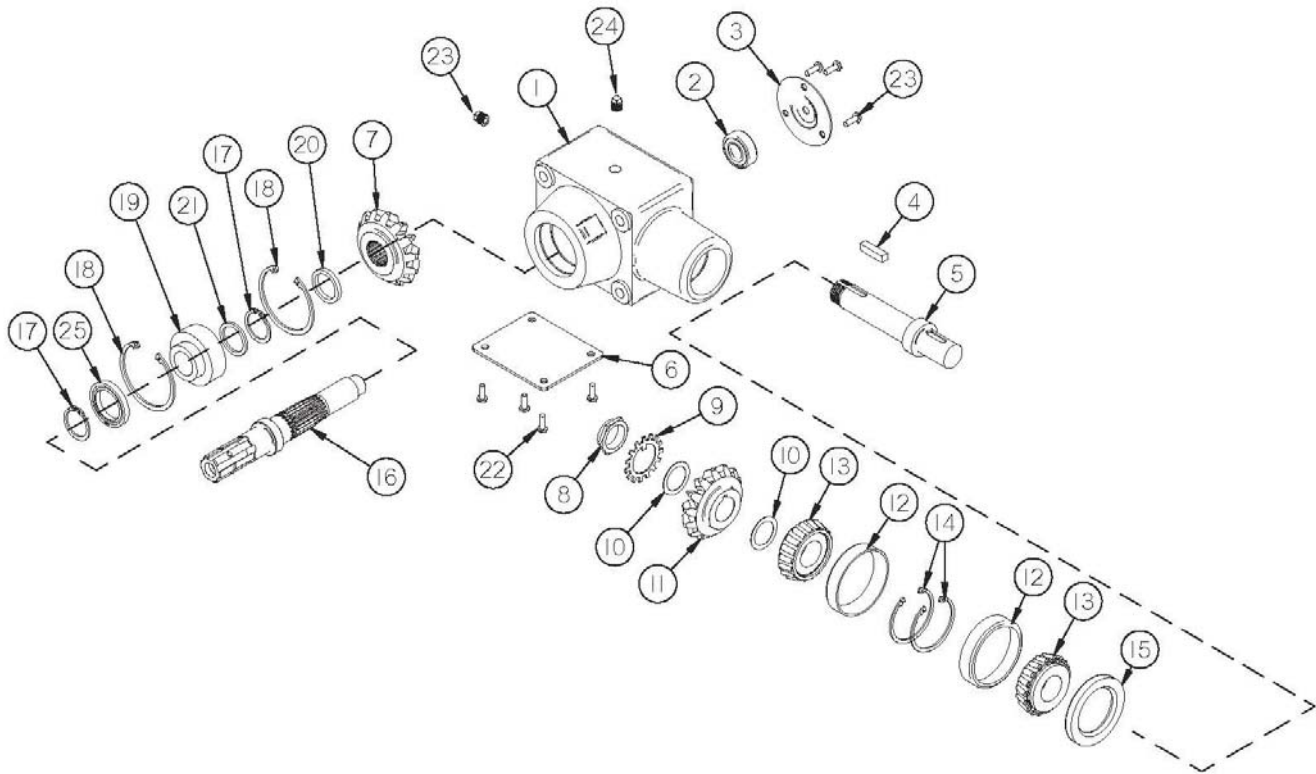

FIGURE 11

BEATER GEARBOX

<u>ITEM</u>	<u>QTY</u>	<u>PART #</u>	<u>DESCRIPTION</u>
1	1	SD69	GEARBOX HOUSING
2	1	GM259	BEARING (6205C3)
3	1	GM258	COVER
4	1	GM264	5/16" X 1" KEY
5	1	SD245	INPUT SHAFT
6	1	GM257	SIDE COVER
7	1	GM267	BEVEL GEAR (SPLINED)
8	1	GM260	BEARING LOCK NUT (N-06)
9	1	GM261	BEARING LOCK WASHER (W-06)
10	2	GM262	INPUT SHIM
11	1	GM263	BEVEL GEAR (KEYED)
12	2	3G18	RACE (15245)
13	2	SD71	BEARING (15123)
14	2	SD72	RETAINING RING (N5000-244)
15	1	SD257	SEAL (471831)
16	1	SDSH30	OUTPUT SHAFT
17	2	SD85	RETAINING RING (5100-137)
18	2	G55	RETAINING RING
19	1	SD75	BEARING (207P)
20	1	SD103	GEARBOX BEARING SPACER
21	1	SD104	GEARBOX GEAR SPACER
22	7	YBHH10105	BOLT, 5/16" X 3/4" GR. 5
23	1	58498	1/2" PIPE PLUG SH
24	1	3G20	PLASTIC VENT PLUG
25	1	8595	SEAL
*	1	SD237	COMPLETE GEARBOX

NOTE: * MEANS NOT SHOWN

FIGURE 12
WORM GEARBOX

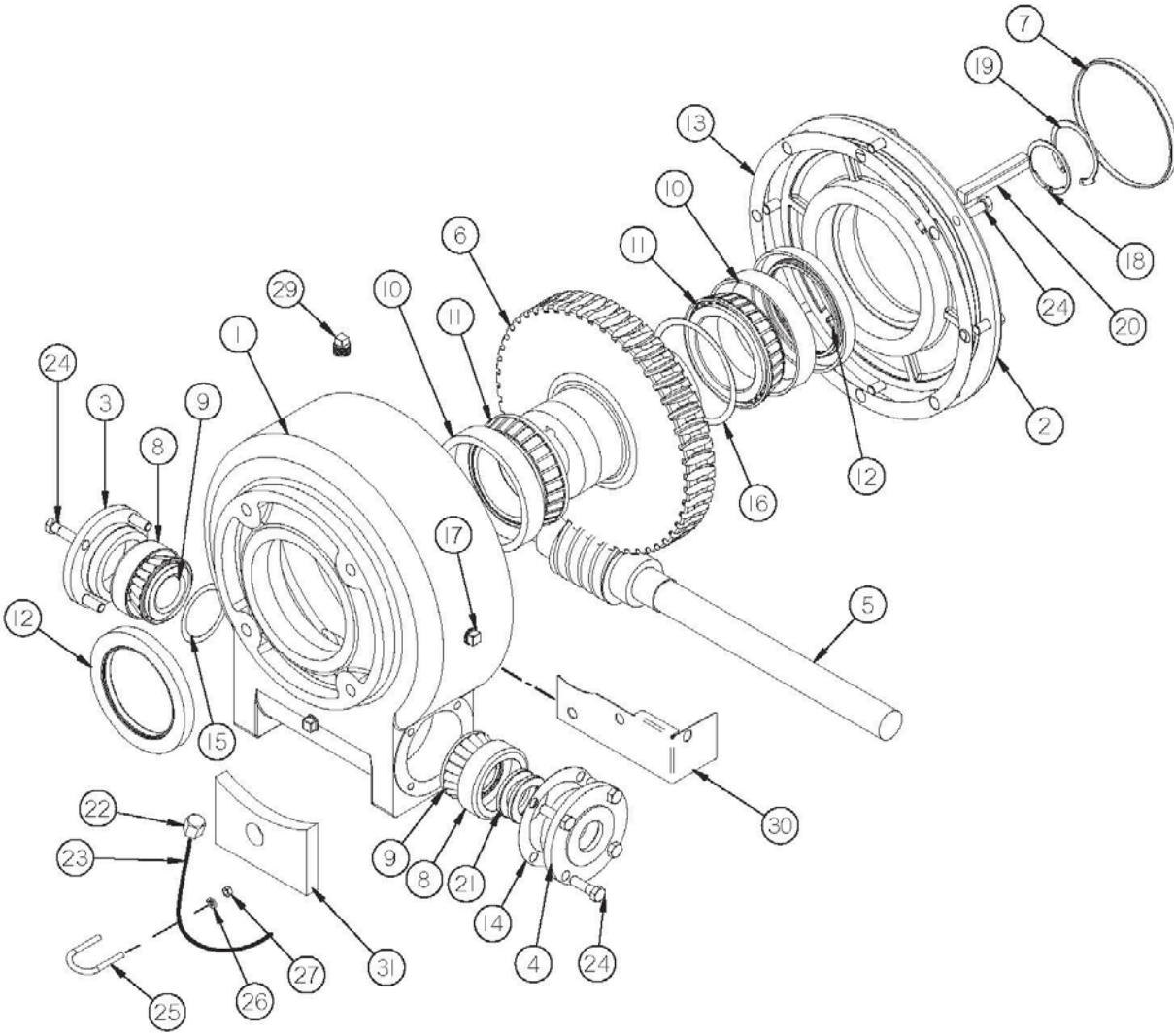

FIGURE 12

WORM GEARBOX

<u>ITEM</u>	<u>QTY</u>	<u>PART #</u>	<u>DESCRIPTION</u>
1	1	SD116	HOUSING
2	1	SD117	OUTPUT COVER
3	1	SD118	ENDCAP, SOLID
4	1	SD119	ENDCAP, THRU
5	1	SD246	INPUT WORM SHAFT
6	1	SD121	GEAR WHEEL
7	1	SD122	CAP
8	1	SD123	RACE
9	1	SD124	BEARING
10	2	SD125	RACE
11	1	SD126	BEARING
12	1	SD127	SEAL, OUTPUT
13	1	SD128	GASKET, COVER
14	1	SD129	GASKET, INPUT
15	1	SD130	INPUT SHIM
16	1	SD131	OUTPUT SHIM
17	2	58498	HEX PLUG
18	1	SD135	RETAINING RING (5108-200)
19	1	SD136	RETAINING RING (5008-250)
20	1	SD137	KEY 1/2" SQUARE X 3-1/2"
21	1	SD138	SEAL, INPUT
22	1	SD139	CAP (5406-C-8)
23	1	SD258	FILLER HOSE 10-1/2" (1/2" MP TO 1/2" MP)
24	16	YBHH12010	BOLT, 3/8" X 1" GR. 5
25	1	YBPU08003	PIPE U BOLT, 1/4"-20 X 1/2" ZINC
26	2	YWLO08005	WASHER, LOCK, 1/4"
27	2	YNHX08005	HEX NUT, 1/4"-20
28	1	SD133	BUSHING 1/2"-14 TO 1/8"-27
29	1	SD134	VENT
*	1	SD230	COMPLETE GEARBOX
30	1	SD316	WORM BOX SHIELD
31	1	56966	FOAM BLOCK

NOTE: * MEANS NOT SHOWN

FIGURE 13
REAR UNLOAD ASSEMBLY

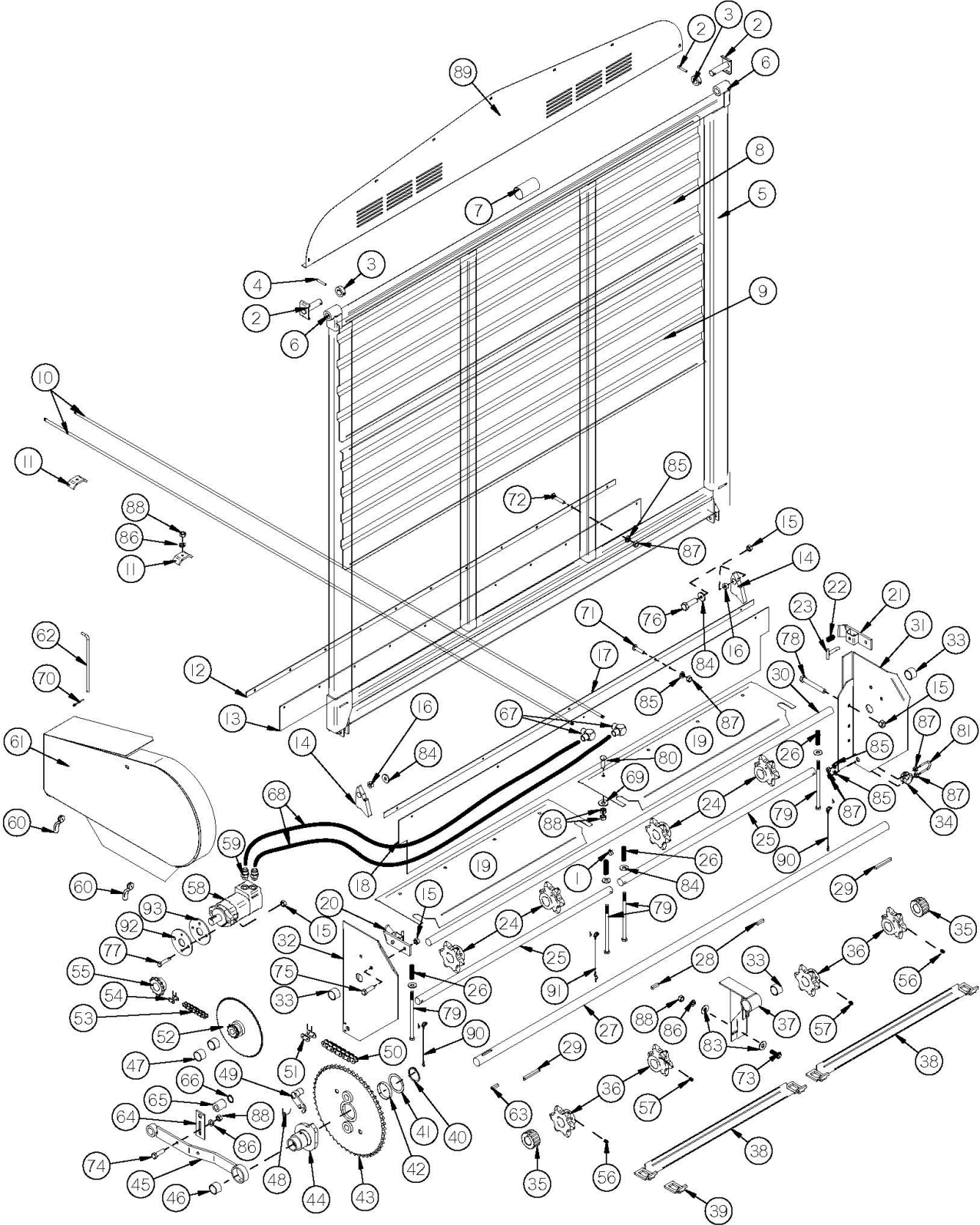

FIGURE 13

REAR UNLOAD ASSEMBLY

<u>ITEM</u>	<u>QTY</u>	<u>PART #</u>	<u>DESCRIPTION</u>
1	1	HGV72	CUSHION WIRE CLAMP
2	2	PB129	HINGE PIN
3	2	PB130	QUEEN PIN HOLDER
4	2	YPEX10015	ROLL PIN, 5/16" X 1-3/4"
5	1	60221	BACK DOOR FRAMEWORK
6	2	PB65	HINGE
7	1	PB66	GUARD
8	1	PB23	BACK DOOR FRAMEWORK
9	1	PB24	BACK DOOR BOTTOM STEEL
10	2	PB102	HYDRAULIC PIPE 252"
11	7	23N67	FRONT HOSE BRACKET
12	1	S288	BOX TO UNIT SEAL STRAP
13	1	PB54	RUBBER SEAL
14	2	59883	DOOR LATCH BAR
15	12	YNRL16005	HEX NUT, REVERSIBLE-SIDE LOCK, 1/2"-13
16	2	60088	LATCH SPACER
17	1	IFB59	POLY SHIELD HOLDER
18	1	IFB60	POLY SHIELD
19	2	IFB56	RACK DRIVE SHAFT SEAL
20	1	IFB58	DOOR SAFETY LATCH LEFT
21	1	IFB57	DOOR SAFETY LATCH RIGHT
22	2	IFB110	LATCH SPRING OCS- 81 B -6 MW
23	2	IFB109	ASSY, LATCH PIN
24	4	S60	IDLER SHAFT SPROCKET
25	2	PB89	TIGHTENER SHAFT
26	1	57577	6" DIE SPRING, HEAVY LOAD, 1"X1/2"X6"
27	1	PB253	1-3/4" DRIVE SHAFT
28	2	PB87	KEY, 3/8" SQUARE X 2" LONG
29	2	PB133	KEY, 3/8" SQ. X 4-3/8"
30	1	PB90	IDLER SHAFT
31	1	PB257	REAR DRIVE SHAFT MOUNT RH
32	1	PB256	REAR DRIVE SHAFT MOUNT LH
33	3	S50	BUSHING, DRIVE SHAFT
34	1	F33	SIDE CABLE GUIDE
35	2	PB175	LATCH SPROCKET
36	4	SD213	6 TOOTH STEEL SPROCKET
37	1	PB258	CENTER BEARING BRACKET
38	1	S233	667H PINTLE W/ATT. LINKS
*	1	11S50	667 PINTLE ATTACHMENT LINK RH
*	1	S326	667XH COMPLETE PINTLE APRON 20'
39	1	11S51	667XH PINTLE CONNECTOR LINK
40	1	23N227	SNAP RING
41	1	PB126	CLUTCH SPROCKET WASHER
42	1	PB135	BUSHING 3.00" OD X 2-3/4" ID
43	1	PB193	52T SPROCKET
44	1	PB252	REAR CLUTCH DOG
45	1	PB251	DRIVE SHAFT BRACE
46	1	12V73	BUSHING, BRONZE

NOTE: * MEANS NOT SHOWN

FIGURE 13

REAR UNLOAD ASSEMBLY

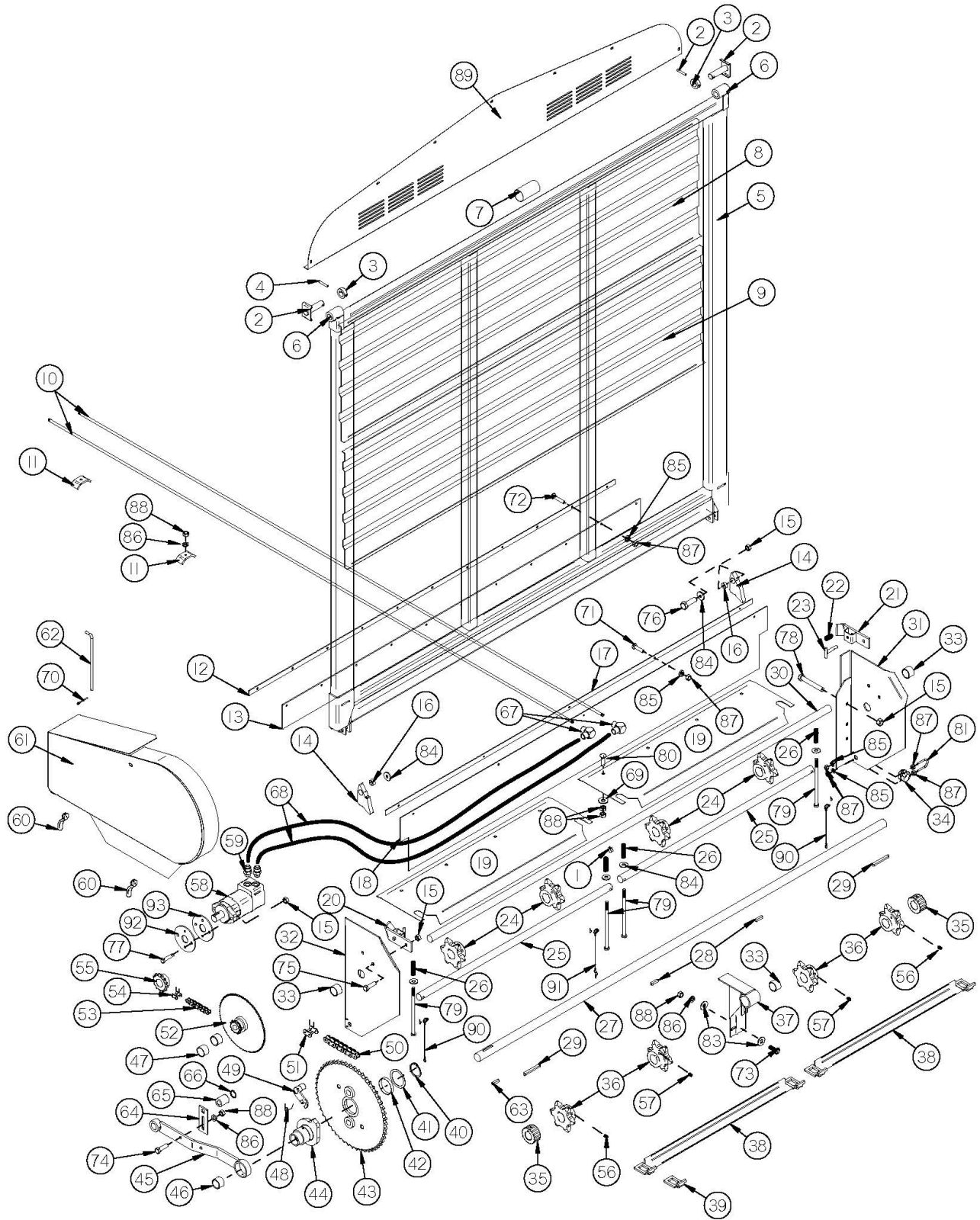

FIGURE 13

REAR UNLOAD ASSEMBLY

<u>ITEM</u>	<u>QTY</u>	<u>PART #</u>	<u>DESCRIPTION</u>
47	2	PB108	BUSHING 1-1/2OD X 1-1/4ID
48	1	YPLY06010	PIN, LYNCH, 3/16" x 1-9/16"
49	1	PB191	CLUTCH PIN
50	1	PB114	#80 ROLLER CHAIN 73 PITCHES
51	1	F157	CONNECTOR LINK WITH CLIP
52	1	PB95	SPROCKET, 84T (50A84)
53	1	SD292	ROLLER CHAIN # 50 X 96 PITCHES AND CONN. LINK
54	1	X61	#50 CONNECTOR LINK
55	1	PB235	SPROCKET 2000 SERIES
56	2	YSKP10010	SET SCREW, SOCKET, KNURLED CUP
57	2	YSKP12010	SET SCREW, SOCKET, KNURLED CUP
58	1	16SV150	HYDRAULIC MOTOR
59	2	GM27	8-10-F5OX-S FITTING
60	2	S192	HANDLE NUT
61	1	PB138	COVER
62	1	PB100	SHIELD HINGE PIN
63	1	56N174	3/8" X 2" W/ ROUND ENDS
64	1	17G69	ASSY, CHAIN TIGHTENER BRACKET
65	1	23N238	CHAIN TIGHTENER ROLLER
66	1	10R32	SNAP RING
67	2	50N135	FEMALE ELBOW, 1/2", 90 DEGREE
68	2	SD308	HYDRAULIC HOSE 1/2" X 60" (139HY-8-8, 1/2MPX)
69	8	S304	TIGHTENER WASHER
70	1	YPCT05010	COTTER PIN, 5/32 X 1-1/2
71	5	YBHH08010	BOLT, 1/4" X 1" GR. 5
72	11	YBHH08035	BOLT, 1/4" X 1-1/4" GR. 5
73	1	YBHH12010	BOLT, 3/8" X 1" GR. 5
74	2	YBHH12035	BOLT, 3/8" X 1-1/4" GR. 5
75	2	YBHH16045	BOLT, 1/2" X 1-1/4" GR. 5
76	2	YBHH16030	BOLT, 1/2" X 1-1/2" GR. 5
77	2	YSHS16015	SOCKET HEAD CAP SCREW, 1/2-13 X 2
78	6	YBHH16115	BOLT, 1/2" X 3-1/2" GR. 5
79	4	57589	TIGHTENER BOLT
80	8	YBCR12015	CARR. BOLT, 3/8" X 1-1/2" GR. 5
81	1	YBPU08005	PIPE U BOLT, 1/4 X 3/4
82	5	YWFL08005	WASHER, FLAT, 1/4" USS
83	2	YWFL12005	WASHER, FLAT, 3/8" USS
84	2	YWFL16005	WASHER, FLAT, 1/2" USS
85	18	YWLO08005	WASHER, LOCK, 1/4"
86	10	YWLO12005	WASHER, LOCK, 3/8"
87	20	YNHX08005	HEX NUT, 1/4"-20
88	26	YNHX12005	HEX NUT, 3/8"-16
89	1	PB72	BACK DOOR TOP PANEL
90	2	57616	LANYARD, 9/64 X 2-11/16 HAIR PIN
91	1	HD225	LANYARD, HITCH
92	1	PB260	MOTOR MOUNT WASHER
93	1	PB261	MOTOR MOUNT WASHER

NOTE: * MEANS NOT SHOWN

FIGURE 14

INDUSTRIAL 2-WAY UNLOAD

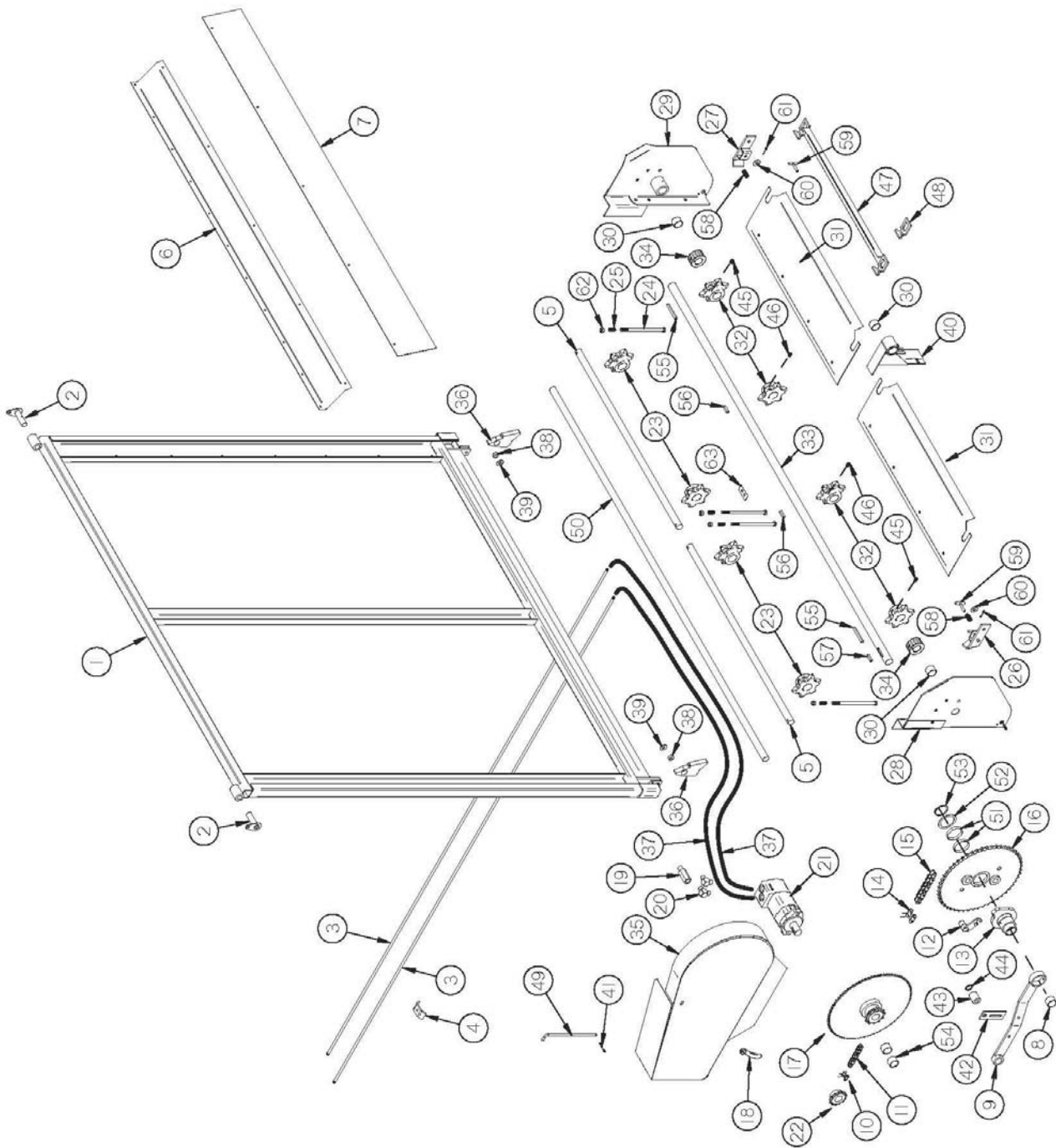

FIGURE 14

INDUSTRIAL 2-WAY UNLOAD

<u>ITEM</u>	<u>22 FT</u>	<u>24 FT</u>	<u>26 FT</u>	<u>DESCRIPTION</u>
1	IFB55	"	"	REAR DOOR FRAMEWORK
2	IFB3	"	"	DOOR HINGE PIN
3	PB101	PB18	PB102	HYDRAULIC PIPE
4	23N67	"	"	PIPE CLAMP
5	PB89	"	"	IDLER SHAFTS
6	IFB59	"	"	POLY SEAL HOLDER
7	IFB60	"	"	POLY SEAL
8	PB134	"	"	BUSHING 2-1/2" OD X 2-1/4" ID X 1" Long
9	PB119	"	"	DRIVE SHAFT BRACE
10	X61	"	"	#50 CONNECTOR LINK
11	PB97	"	"	#50 CHAIN X 90 PITCH
12	PB191	"	"	CLUTCH PIN
13	PB118	"	"	REAR CLUTCH DOG
14	F157	"	"	#80 CONNECTOR LINK
15	PB114	"	"	#80 CHAIN 73 PITCHES
16	PB193	"	"	52 TOOTH SPROCKET
17	PB95	"	"	11 TOOTH TO 84 TOOTH SPROCKET
18	S192	"	"	HANDLE NUT
19	DF18	"	"	CHECK VALVE (1/2")
*	PB185	"	"	CHECK VALVE 3/4" (OPTION)
20	HE58	"	"	ELBOW 1/2" (2)
21	DF18	"	"	HYDRAULIC MOTOR
*	16SV150	"	"	HYDRAULIC MOTOR (OPTION)
22	PB235	"	"	SPROCKET 2000 SERIES
23	S60	"	"	IDLER SHAFT SPROCKET (8 PCS.)
24	YBHH16190	"	"	BOLT, 1/2" X 9-1/2" GR. 5
25	WM210	"	"	SPRING - RED
26	IFB58	"	"	REAR DOOR LOCK LATCH LEFT
27	IFB57	"	"	REAR DOOR LOCK LATCH RIGHT
28	IFB51	"	"	LH DRIVE SHAFT MOUNT
29	IFB52	"	"	RH DRIVE SHAFT MOUNT
30	23N17	"	"	DRIVE SHAFT MOUNT BUSHING
31	IFB56	"	"	DRIVE SHAFT PANEL
32	23N122	"	"	DRIVE SPROCKET (4)

NOTE: " SAME PREVIOUS MODEL

FIGURE 14

INDUSTRIAL 2-WAY UNLOAD

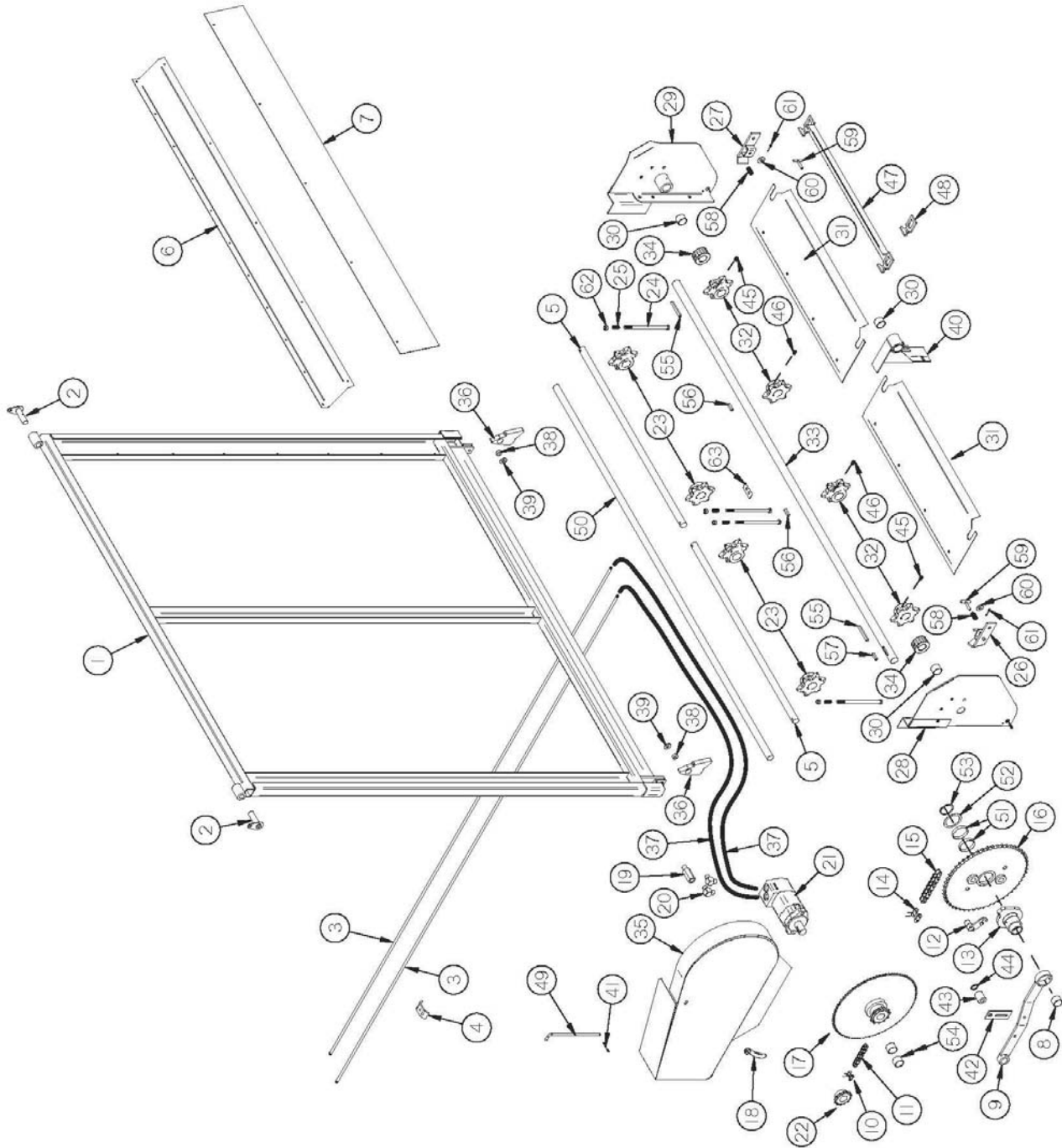

FIGURE 14

INDUSTRIAL 2-WAY UNLOAD

<u>ITEM</u>	<u>PART #</u>			<u>DESCRIPTION</u>
	<u>22 FT</u>	<u>24 FT</u>	<u>26 FT</u>	
33	PB194	"	"	DRIVE SHAFT
34	PB83	"	"	LATCH SPROCKET
35	PB138	"	"	REAR SHAFT SHIELD
36	59883	"	"	DOOR LATCH BAR
37	PB41	"	"	HYDRAULIC HOSE 1/2" X 60"
*	16SV144	"	"	HYDRAULIC HOSE 1/2" X 41" (OPTION)
38	60088	"	"	LATCH SPACER
39	YWFL16005	"	"	WASHER, FLAT, 1/2" USS
40	PB139	"	"	CENTER BEARING BRACKET
41	YPCT05010	"	"	COTTER PIN, 5/32 X 1-1/2
42	17G69	"	"	CHAIN TIGHTENER BRACKET
43	23N238	"	"	CHAIN TIGHTENER ROLLER
44	10R32	"	"	SNAP RING
45	YSKP10010	"	"	SET SCREW, SOCKET, KNURLED CUP
46	YSKP12010	"	"	SET SCREW, SOCKET, KNURLED CUP
47	S233	"	"	SLAT W/ ATT. LINK - 667H PINTLE
*	S324	S325	S326	COMPLETE 667H APRON
48	11S51	"	"	667H PINTLE CONNECTOR LINK
*	11S50	"	"	667H PINTLE ATT. LINK LH OR RH
49	PB100	"	"	SHIELD HINGE PIN
50	PB90	"	"	INSIDE IDLER SHAFT
51	PB135	"	"	BUSHING
52	PB126	"	"	CLUTCH SPROCKET WASHER
53	23N227	"	"	SNAP RING
54	PB108	"	"	BUSHING 1-1/2" OD X 1-1/4" ID X 1-3/4"
55	PB133	"	"	KEY 3/8" X 4-3/8" SQUARE
56	PB87	"	"	KEY 3/8" X 2" SQUARE
57	PB136	"	"	KEY 3/8" X 2" SQUARE HARDENED W/ ROUND ENDS
58	IFB110	"	"	DOOR LATCH SPRING
59	IFB109	"	"	DOOR LATCH PIN
60	YWFL16005	"	"	WASHER, FLAT, 1/2" USS
61	YPCT05010	"	"	COTTER PIN, 5/32 X 1-1/2
62	YNTL16005	"	"	HEX NUT, TOP LOCK, 1/2"-13
63	PB196	"	"	LOCK TAB

NOTE: " SAME PREVIOUS MODEL

FIGURE 15
4TH BEATER OPTION

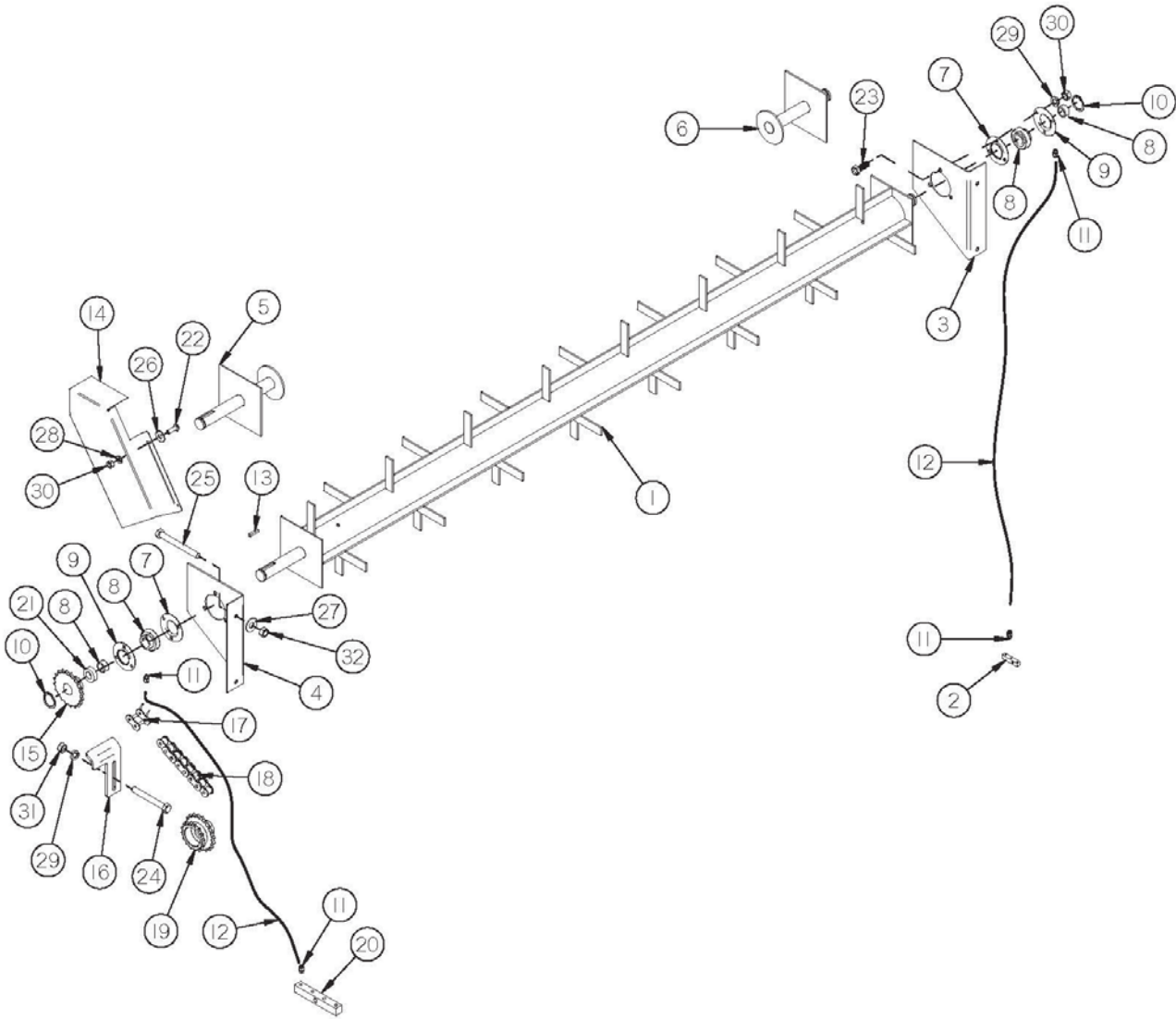

FIGURE 15

4TH BEATER OPTION

<u>ITEM</u>	<u>QTY</u>	<u>PART #</u>	<u>DESCRIPTION</u>
1	1	S263	BEATER
2	1	SD83	GREASE BLOCK (3 PORT)
3	1	S264	LEFT HAND BEATER PANEL
4	1	S261	RIGHT HAND BEATER PANEL
5	1	S265	RIGHT HAND BEATER SHAFT
6	1	S451	LEFT HAND BEATER SHAFT
7	2	F14	BEARING FLANGE
8	2	12N122	BEARING W/ LOCK COLLAR ASSY.
9	2	F114	BEARING FLANGE W/ZERK
10	2	F73	SNAP RING
11	4	S47	GREASE LINE FITTING
12	2	SD142	GREASE LINE
13	1	G23A	SQUARE KEY, 5/16" X 1-1/4"
14	1	SD143	4TH BEATER SHIELD
15	1	S26	BEATER SPROCKET (20 T
16	1	SD144	CHAIN TIGHTENER
17	1	X61	#50 CONNECTOR LINK
18	1	SD145	4TH BEATER CHAIN (#50 X 72 PITCHES)
19	1	S266	3RD BEATER SPROCKET (#50 X 20 TOOTH TO 16 TOOTH)
20	1	SD146	GREASE BLOCK (4 PORT)
21	1	S262	SPACER
22	2	YBHH08100	BOLT, 1/4" X 3/4" GR. 5
23	6	YBHH12010	BOLT, 3/8" X 1" GR. 5
24	1	YBHH12120	BOLT, 3/8" X 3" GR. 5
25	4	YBHH12145	BOLT, 3/8" X 3-1/2" GR. 5
26	2	YWFL08005	WASHER, FLAT, 1/4" USS
27	4	YWFL12005	WASHER, FLAT, 3/8" USS
28	2	YWLO08005	WASHER, LOCK, 1/4"
29	7	YWLO12005	WASHER, LOCK, 3/8"
30	2	YNHX08005	HEX NUT, 1/4"-20
31	7	YNHX12005	HEX NUT, 3/8"-16
32	4	YNRL12005	HEX NUT, REVERSIBLE-SIDE LOCK, 3/8"-16

FIGURE 16

LIGHT HARNESS

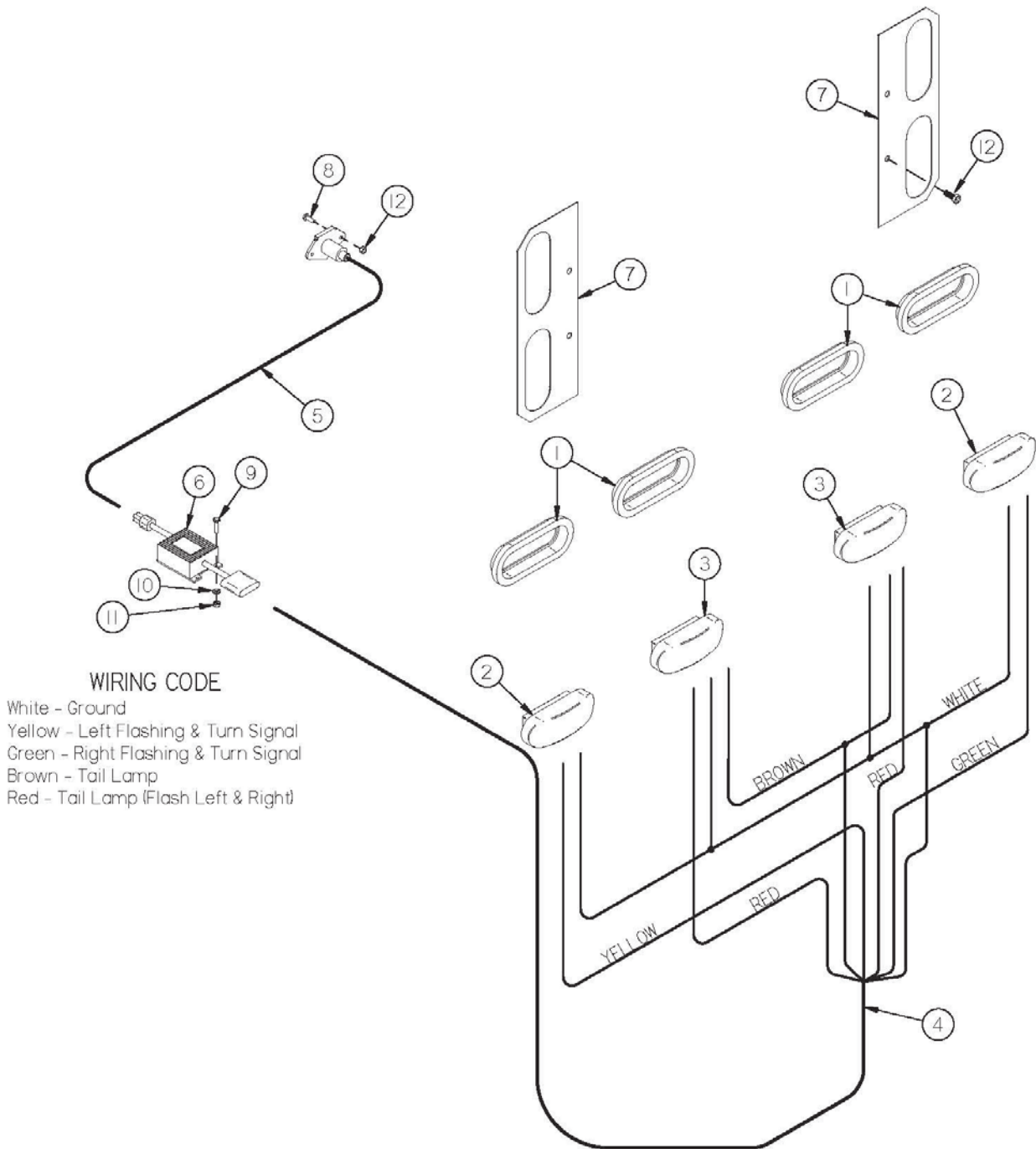

FIGURE 16

LIGHT HARNESS

<u>ITEM</u>	<u>QTY</u>	<u>PART #</u>	<u>DESCRIPTION</u>
1	4	S308	RUBBER LIGHT MOUNT
2	2	S309	AMBER LIGHT
3	2	S310	RED LIGHT
4	1	PB232	LIGHT HARNESS (6 WIRE)
5	1	S443	16' LONGITUDINAL CORD (4 WIRE)
*	1	S442	18' LONGITUDINAL CORD (4 WIRE)
*	1	S439	20' LONGITUDINAL CORD (4 WIRE)
7	1	S441	LIGHT MODULE
8	2	PB111	TAILLIGHT BRACKETS (2-WAY ONLY)
*	1	PB239	16' COMPLETE LIGHT ASSEMBLY (LESS OPTIONAL TRACTOR CORD)
*	1	PB240	18' COMPLETE LIGHT ASSEMBLY (LESS OPTIONAL TRACTOR CORD)
*	1	PB241	20' COMPLETE LIGHT ASSEMBLY (LESS OPTIONAL TRACTOR CORD)
9	2	YBHH08015	BOLT, 1/4" X 1/2" GR. 5
10	3	YBHH08010	BOLT, 1/4" X 1" GR. 5
11	3	YWLO08005	WASHER, LOCK, 1/4"
12	5	YNHX08005	HEX NUT, 1/4"-20
13	6	YSHW10010	5/16"-18 X 1-1/4" HEX WASHER SLOT TYPE F ZINC THREAD CUTTING SCREW
*	1	TLPC	TRANSPORT LIGHT CORD

NOTE: * MEANS NOT SHOWN

FIGURE 17

UNIT HARNESS ROUTING

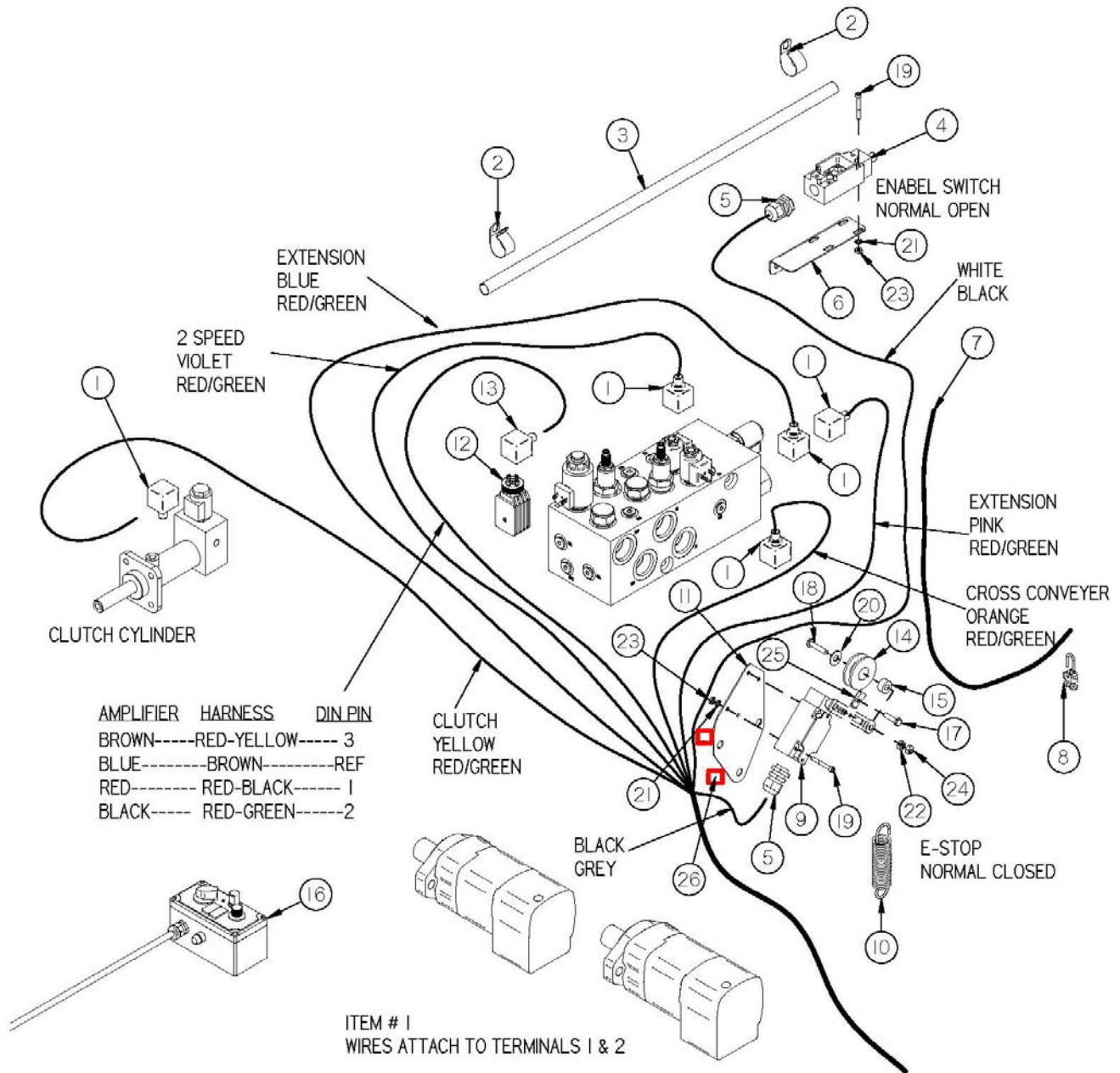

AMPLIFIER HARNESS	DIN PIN
BROWN-----RED-YELLOW-----	3
BLUE-----BROWN-----	REF
RED-----RED-BLACK-----	1
BLACK-----RED-GREEN-----	2

FIGURE 17

UNIT HARNESS ROUTING

<u>ITEM</u>	<u>QTY</u>	<u>PART #</u>	<u>DESCRIPTION</u>
1	5	LW285	DIN CONNECTOR
2	2	HGV72	WIRE CLAMP #12
3	1	SD251	WIRE SHIELD
4	1	SD252	MICRO-SWITCH (GLAA01C)
5	2	GD23	STRAIN-RELIEF
*	2	56120	STRAIN RELIEF LOCK NUT, 1/2"
6	1	SD250	MICRO-SWITCH MOUNT
7	1	SD253	SAFETY CABLE
8	1	BFR220	CABLE CLAMP
9	1	57244	MICRO SWITCH W / SAFETY ARM
10	1	LW111	SPRING
11	1	SD255	SAFETY LIMIT SWITCH MOUNT
12	1	SD293	FLOW CONTROL AMPLIFIER
13	1	SD294	DIN CONNECTOR
14	1	BFR292	POLY PULLEY SMALL HOLE
15	1	ST81	EXTENSION SPACER
16	1	SD321	SDC CONTROL BOX
17	1	YBHH08010	BOLT, 1/4" X 1" GR. 5
18	1	YBHH08025	BOLT, 1/4" X 1-1/2" GR. 5
19	8	YSHS64008	SOCKET HEAD CAP SCREW, #10-32 X 1-1/2" BLACK OXIDE
20	1	YWFL10005	WASHER, FLAT, 5/16" USS
21	8	YWSI64005	WASHER, LOCK, STAR, INTERNAL/EXTERNAL, #10
22	1	YNHX08005	HEX NUT, 1/4"-20
23	8	YNHX64005	HEX NUT, #10-32
24	1	YNTL08005	HEX NUT, TOP LOCK, 1/4"-20
25	1	YNUN08005	EXTRUDED U NUT, 1/4"-20, BLACK
26	3	K94	SPACER CHAIN TIGHTENER

NOTE: * MEANS NOT SHOWN

FIGURE 18
CONTROL BOX

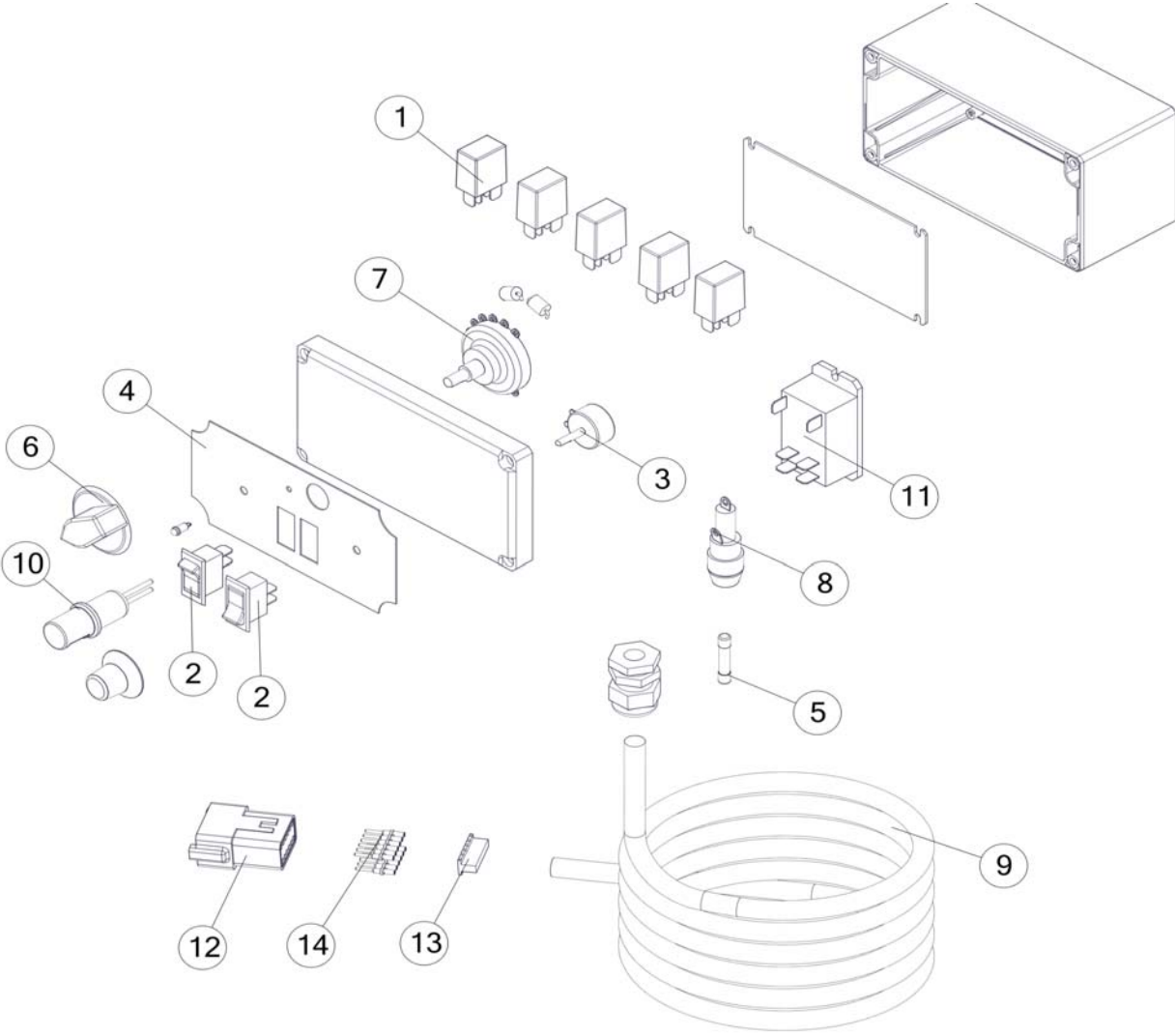

FIGURE 18
CONTROL BOX

<u>ITEM</u>	<u>QTY</u>	<u>PART #</u>	<u>DESCRIPTION</u>
1	5	59189	RELAY SPDT
2	2	59191	ROCKER SWITCH
3	1	59192	POTENTIOMETER 10K
4	1	59193	NAMEPLATE
5	1	59194	FUSE 12 AMP.
6	1	59198	SWITCH KNOB
7	1	59200	6 POSITION SELECTOR
8	1	59202	FUSE HOLDER
9	1	59203	18 GA. 12 CONDUCTOR
10	1	59205	INSTRUMENT LIGHT HOLDER
11	1	59207	RELAY DPDT
12	1	SE4153	12 PIN DEUTSCH RECEPTACLE
13	1	SE4154	DEUTSCH LOCKING WEDGE FOR 12 PIN RECEPTACLE
14	12	SE215	DEUTSCH PIN, SOLID, 14-16 GA.

NOTE: * MEANS NOT SHOWN

FIGURE 19

MAIN WIRING HARNESS

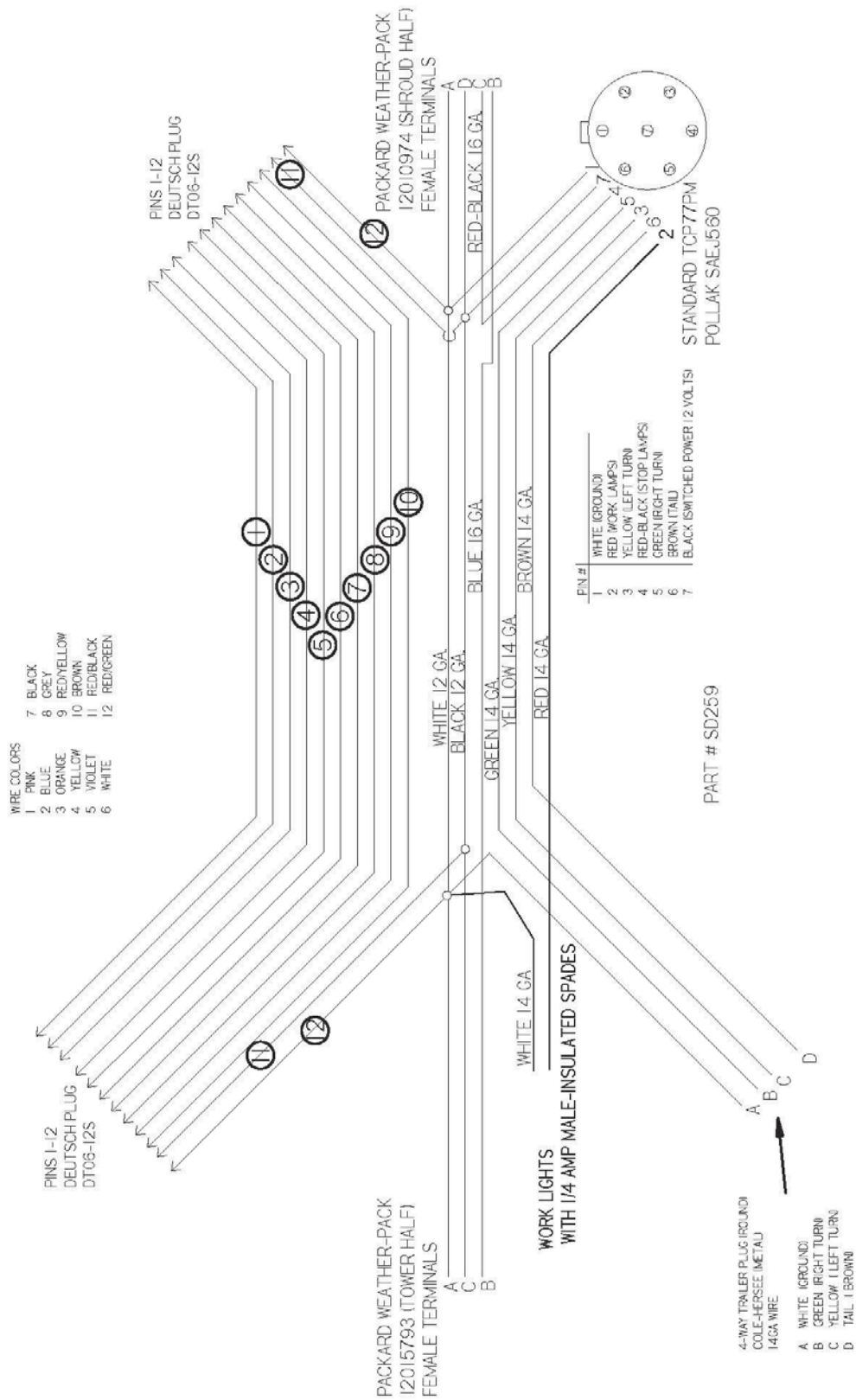

FIGURE 20

UNIT HARNESS

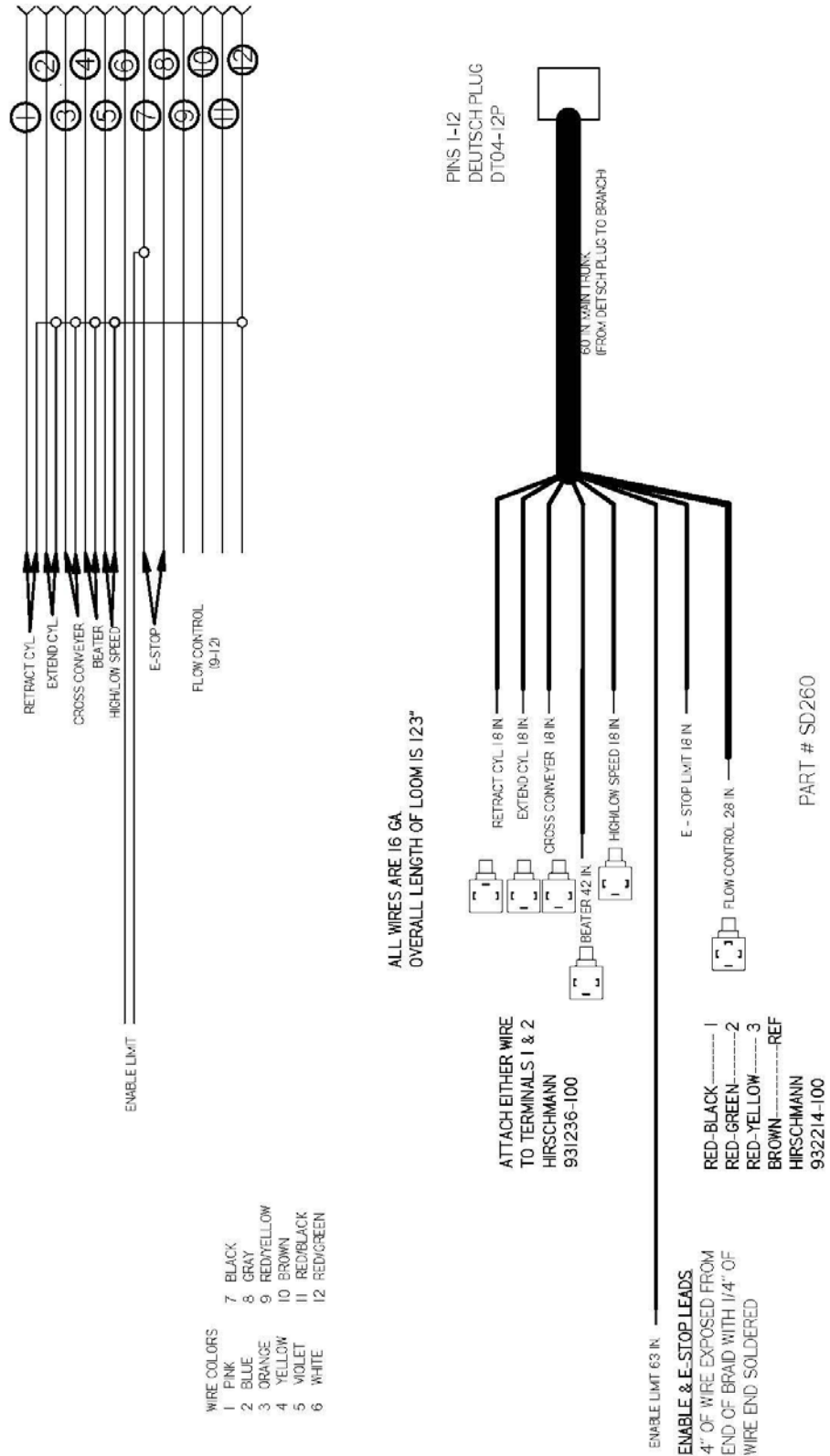

FIGURE 21

EXTENSION HYDRAULICS

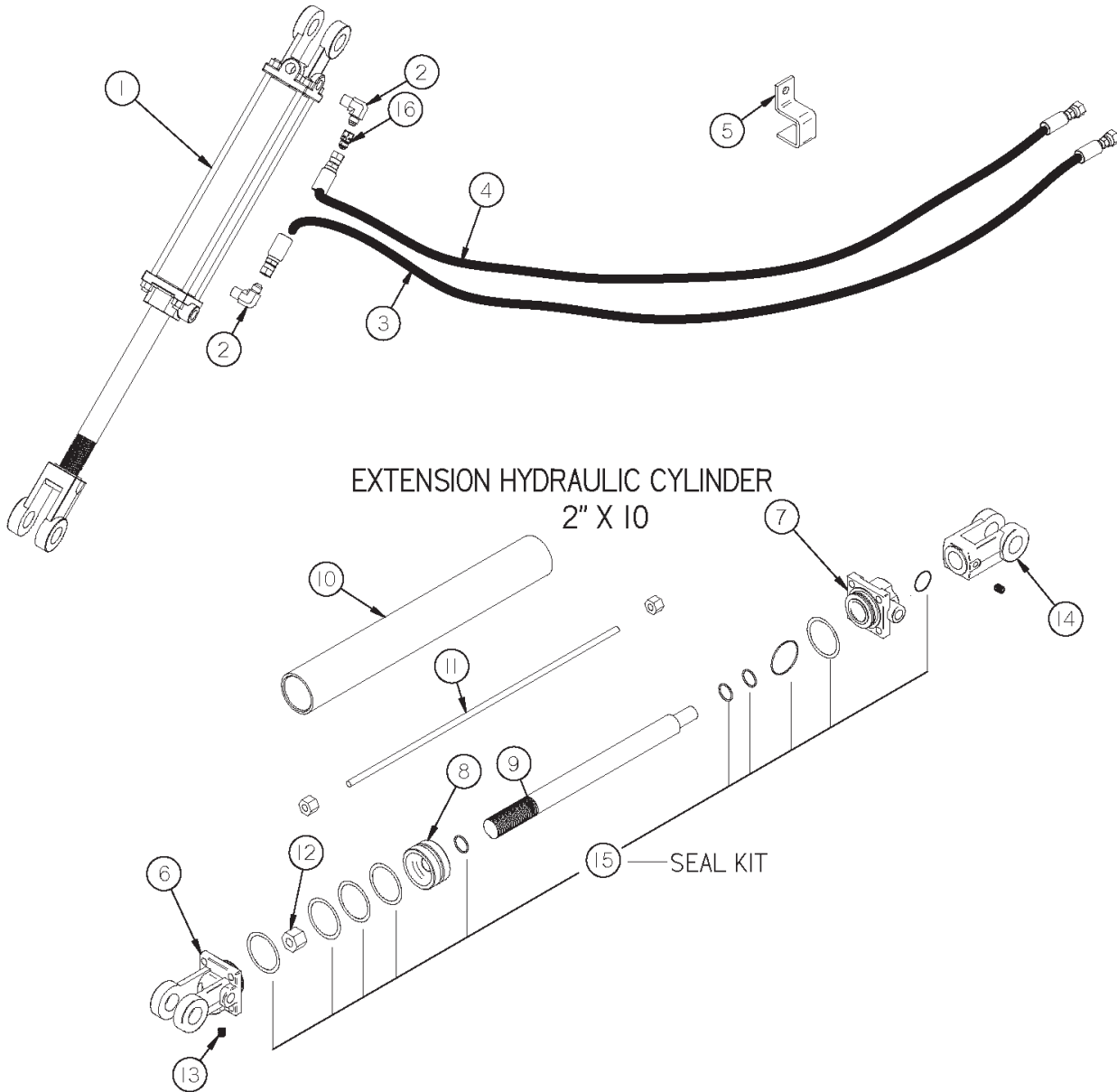

FIGURE 21

EXTENSION HYDRAULICS

<u>ITEM</u>	<u>QTY</u>	<u>PART #</u>	<u>DESCRIPTION</u>
1	1	16SV171	2" x 10" CYLINDER
*	1	56000	2" X 10" HYDRAULIC CYLINDER
2	2	CHM164	MALE CONNECTOR (6-6 CTX)
3	1	SD271	HYDRAULIC HOSE 3/8" X 133" (106HY-6-6, 106HY-6-6)
4	1	SD272	HYDRAULIC HOSE 3/8" X 116" (106HY-6-6, 106HY-6-6)
5	4	HE14	HOSE CLAMP
6	1	23N142	CLEVIS CAP
*	1	56174	ROD CAP FOR 2" CYLINDER
7	1	23N143	ROD CAP
8	1	23N144	PISTON
*	1	56180	PISTON FOR 2" CYLINDER
9	1	16SV168	PISTON NUT
10	1	16SV169	TUBE
11	4	16SV170	TIE ROD
12	1	23N148	PISTON NUT
13	2	23N149	PLUG
14	1	23N150	ROD CLEVIS
15	1	23N151	SEAL KIT
*	1	56187	SEAL KIT FOR 2" CYLINDER
16	1	58144	FITTING 6 XHX7-S .062 ORIFICE

NOTE: * MEANS NOT SHOWN

FIGURE 22
OPTIONAL AIR GATE DELAY

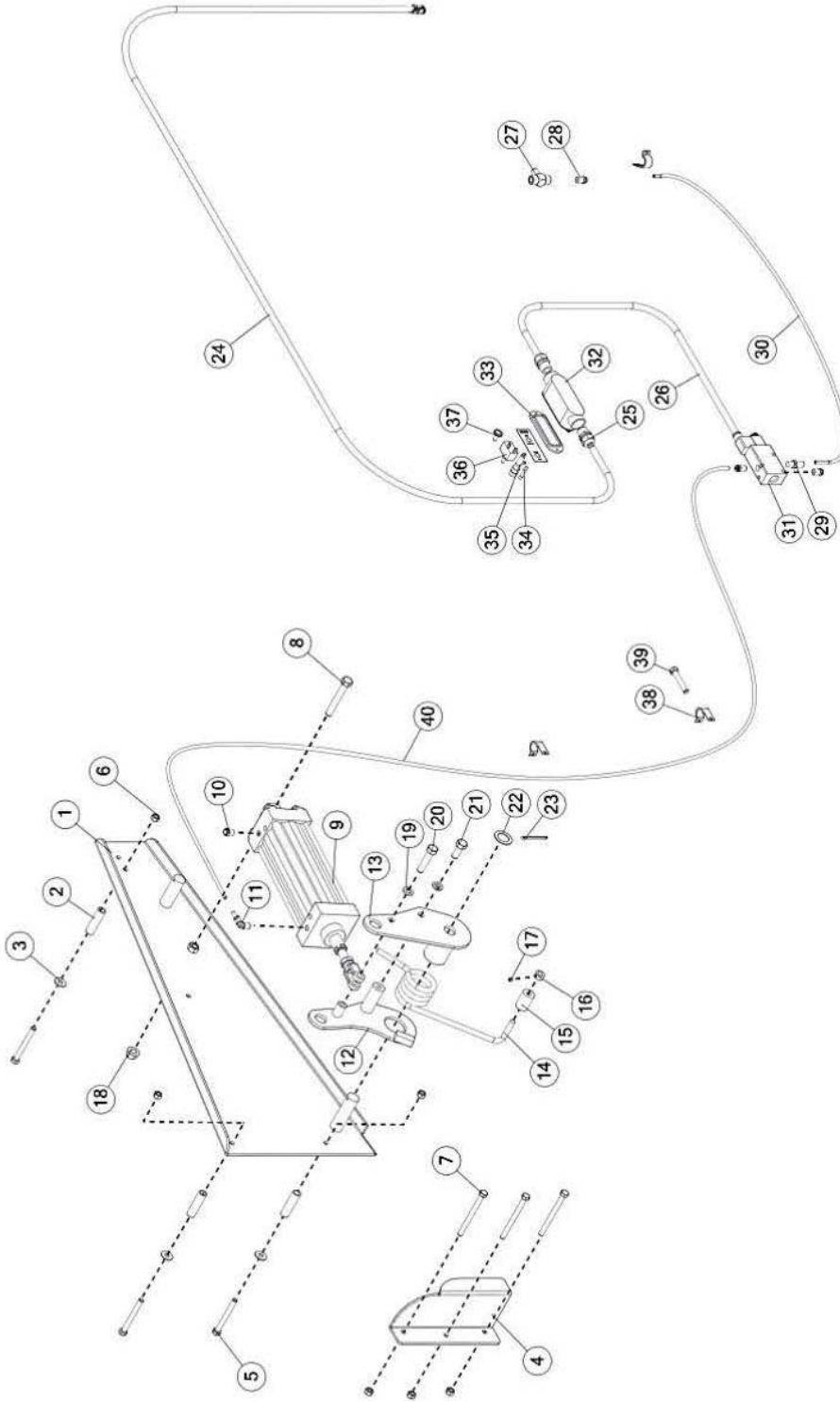

FIGURE 22

OPTIONAL AIR GATE DELAY

<u>ITEM</u>	<u>QTY</u>	<u>PART #</u>	<u>DESCRIPTION</u>
1	1	60257	PIN WELDMENT
2	3	60404	STAKE SPACER
3	3	YWFL12005	WASHER, FLAT, 3/8 USS
4	1	60169	GATE DELAY STOP ANGLE
5	3	YBHH12145	BOLT, 3/8 X 3-1/2 GR 5
6	6	YNRL12005	HEX NUT, REVERSIBLE-SIDE LOCK, 3/8-16
7	3	YBHH12185	BOLT, 3/8 X 4-1/2 GR 5
8	1	YBHH16115	BOLT, 1/2 X 3-1/2 GR 5
9	1	GD52	3-1/4" X 6" AIR CYL COMPLETE
10	1	GD8	1/4" VENT PLUG
11	1	GD5	MALE ELBOW, 1/4"
12	1	60266	SPRING MOUNT BOLT WELDMENT
13	1	60263	SPRING HOLDER
14	1	60261	TORSION SPRING
15	1	60211	ROLLER
16	1	60133	SPRING SET COLLAR
17	1	YSKP08005	SET SCREW, SOCKET, KNURLED CUP PT, 1/4 X 1/4
18	1	YNFG16005	HEX NUT, FLANGED-LOCK, 1/2-13 GRADE F (ZINC)
19	2	YWLO16005	WASHER, LOCK, 1/2
20	1	YBHH16095	BOLT, 1/2 X 2-1/4 GR 5
21	1	YBHH16045	BOLT, 1/2 X 1-1/4 GR 5
22	1	S345	PULLEY SPACER
23	1	YPCT06020	COTTER PIN, 3/16 X 2
24	1	GD53	VALVE CORD
25	2	GD23	STRAIN RELIEF (CONNECTOR)
26	1	GD13	10 FT. 2 WIRE CABLE
27	1	GD43	FEMALE TEE
28	2	GD6	MALE COUPLER, 1/4"
29	1	GD7	1/4" VENT PLUG (CONE SHAPED)
30	1	GD38	1/4" D.O.T. AIR TUBING X 10'
31	1	GD16	3-WAY AIR VALVE (COMPLETE)
32	1	16SV316	CONTROL BOX
33	1	16SV318	CONTROL BOX COVER
34	1	16SV232	FUSE
35	1	16SV231	FUSE HOLDER
36	1	16SV233	CLEAN OUT DOOR SWITCH
37	1	16SV235	SWITCH BOOTS
38	3	HGV162	RUBBER CUSHION CLAMP
39	3	YBHH12100	BOLT, 3/8 X 2-1/4 GR 5
40	1	GD10	1/4" D.O.T. AIR TUBING
*	2	YSHW10020	HWH TCS "F", 5/16-18 X 1-1/2

FIGURE 23
OPTIONAL HYDRAULIC GATE DELAY

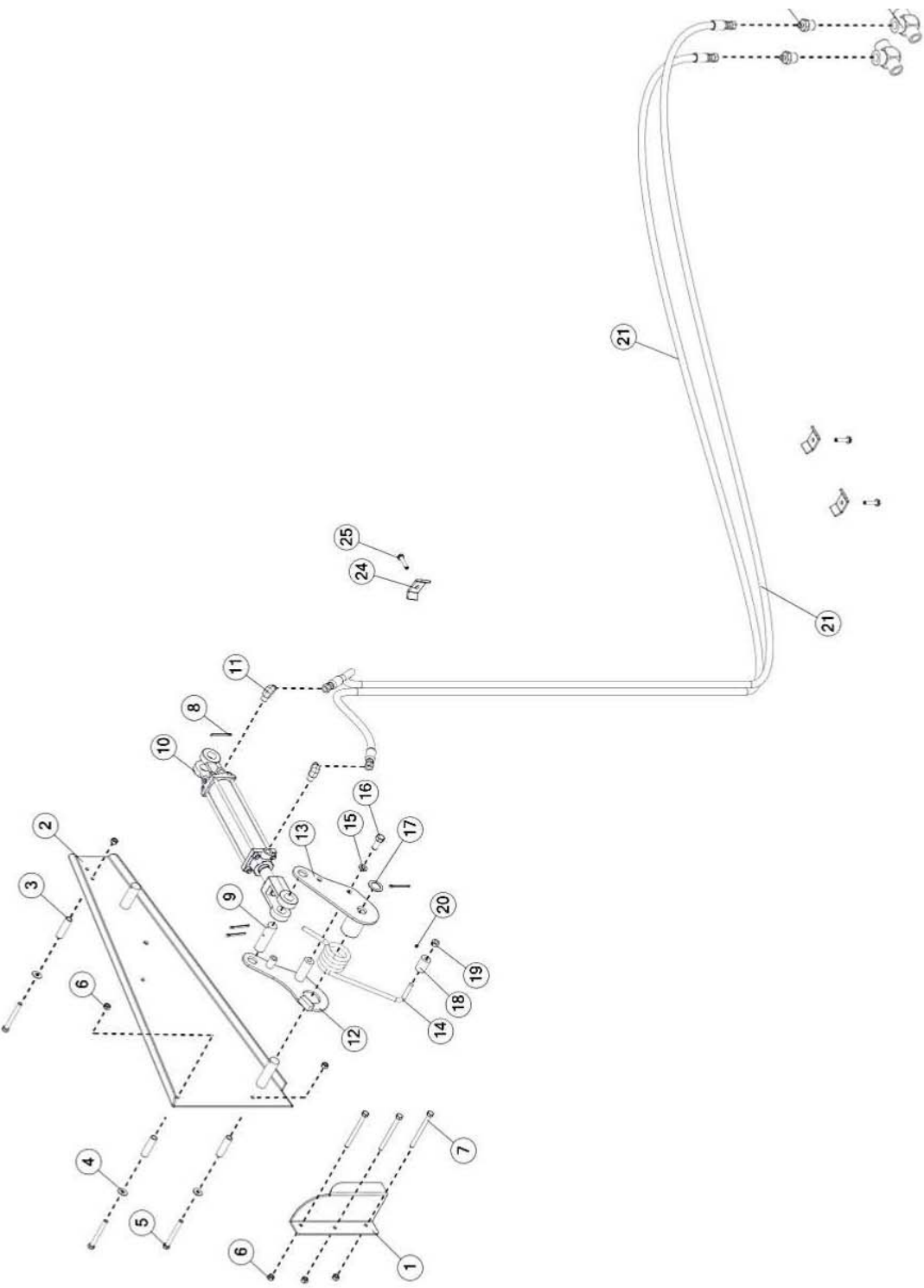

FIGURE 23

OPTIONAL HYDRAULIC GATE DELAY

<u>ITEM</u>	<u>QTY</u>	<u>PART #</u>	<u>DESCRIPTION</u>
1	1	60169	GATE DELAY STOP ANGLE
2	1	60257	PIN WELDMENT
3	3	60404	STAKE SPACER
4	3	YWFL12005	WASHER, FLAT, 3/8 USS
5	3	YBHH12145	BOLT, 3/8 X 3-1/2 GR 5
6	6	YNRL12005	HEX NUT, REVERSIBLE-SIDE LOCK, 3/8-16
7	3	YBHH12185	BOLT, 3/8 X 4-1/2 GR 5
8	4	YPCT06020	COTTER PIN, 3/16 X 2
9	1	60192	GATE DELAY CYLINDER PIN
10	1	55999	2" X 8" HYDRAULIC CYLINDER
11	2	CHM164	MALE ELBOW CTX ~ 6-6 CTX
12	1	60266	SPRING MOUNT BOLT WELDMENT
13	1	60263	SPRING HOLDER
14	1	60261	TORSION SPRING
15	1	YWLO16005	WASHER, LOCK, 1/2
16	1	YBHH16045	BOLT, 1/2 X 1-1/4 GR 5
17	1	S345	PULLEY SPACER
18	1	60211	ROLLER
19	1	60133	SPRING SET COLLAR
20	1	YSKP08005	SET SCREW, SOCKET, KNURLED CUP PT, 1/4 X 1/4
21	2	60322	HOSE- GATE DELAY
22	2	60321	CONNECTOR, MALE, NPTF TO JIC
23	2	33SV71	SERVICE TEE, 3/4"
24	3	23N67	FRONT HOSE BRACKET
25	3	YSHW10020	HWH TCS "F", 5/16-18 X 1-1/2

FIGURE 24

TIE-DOWN

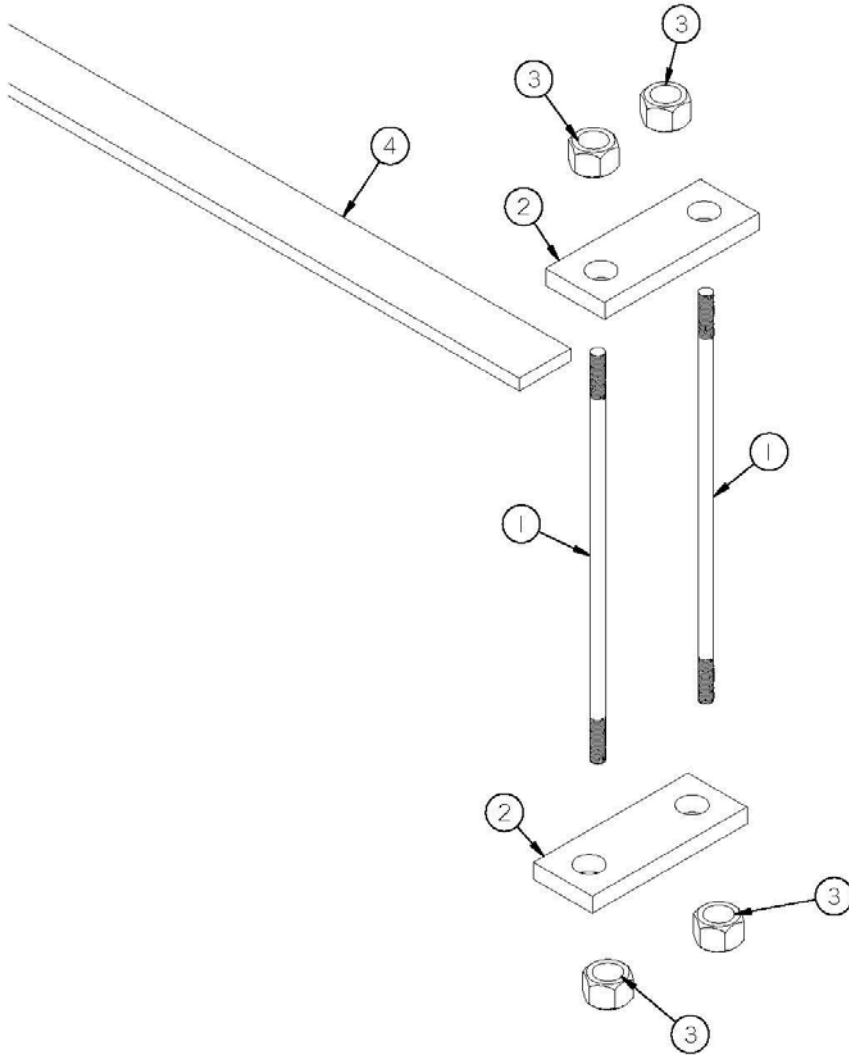

<u>ITEM</u>	<u>QTY</u>	<u>PART #</u>	<u>DESCRIPTION</u>
1	16	FBC6	MOUNT BOLT (24")
2	16	FBC5	CHASSIS MOUNT PLATE
3	32	YNNY24006	HEX NUT, NYLON LOCKNUT, 3/4" (FINE)
4	2	S509	CHASSIS SPACER 1" x 4" x 22'

NOTE: * (AS SHOWN ON 22' BOX)

FIGURE 25

MANIFOLD

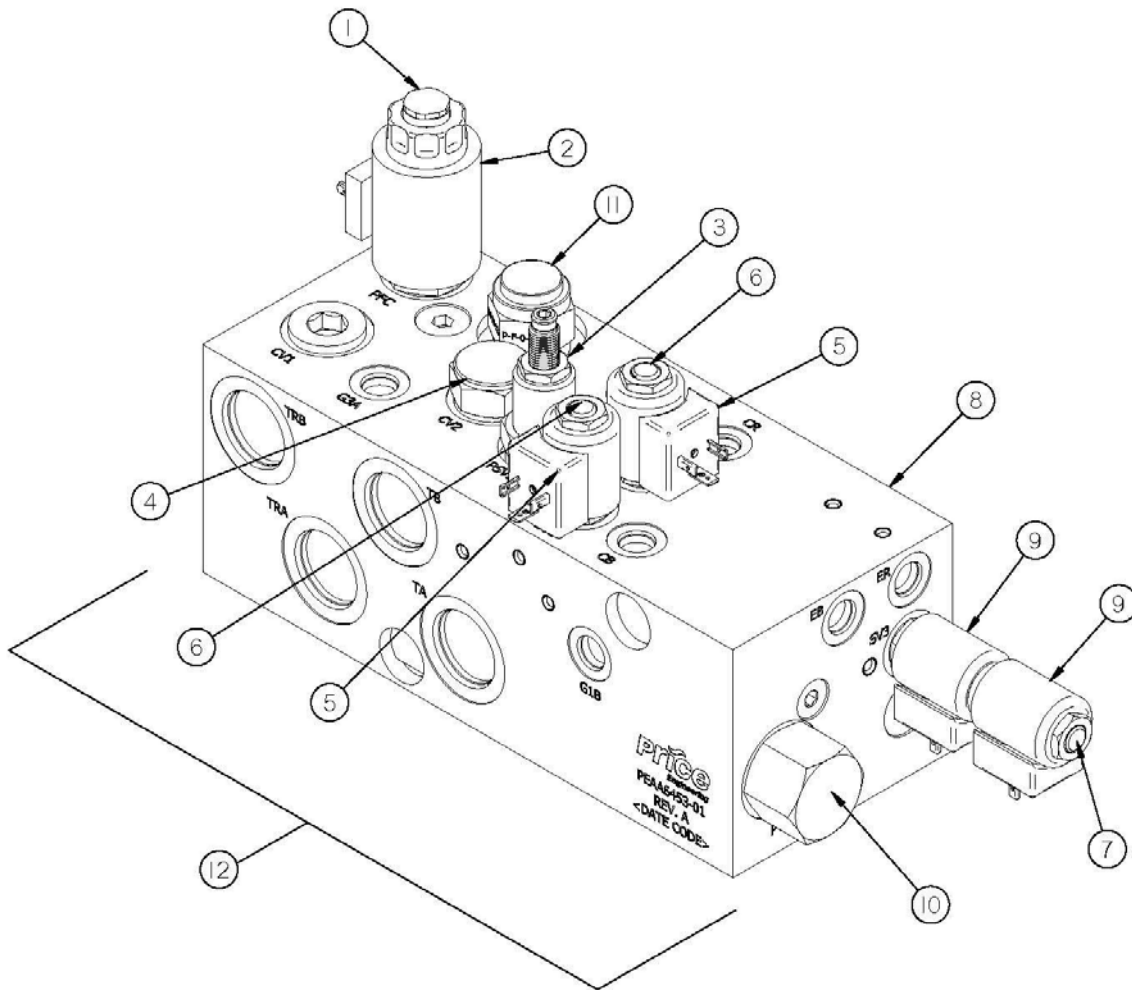

ITEM	QTY	PART #	DESCRIPTION
1	1	SD295	CARTRIDGE-PROPORTIONAL FLOW CONTROL, N.O.
2	1	SD296	COIL, PROPORTIONAL, 12 VOLT DC, DIN 43650 CONNECTOR
3	1	SD297	CARTRIDGE- PRESSURE SEQUENCE VALVE, 1000 PSI SET
4	2	SD298	CARTRIDGE - CHECK VALVE, POPPET TYPE, 2.5 PSI CRACKING
5	2	SD299	TOUGHCOIL, DIN 43650-A, 12 VOLT DC, 210 BAR
6	2	SD300	CARTRIDGE- DIRECTIONAL, 3 WAY 2 POS, DIRECT ACTING SPOOL TYPE
7	1	SD301	CARTRIDGE - DIRECTIONAL, 4 WAY 3 POS, ALL PORTS BLOCKED MANIFOLD BLOCK
8	1	SD302	TOUGHCOIL, DIN 43650-A, 12 VOLT DC, 350 BAR
9	2	SD303	CARTRIDGE-PILOT TO SHIFT, 3 WAY 2 POSITION, 160 PSI SHIFT PRESSURE
10	1	SD304	
11	1	56636	CARTRIDGE-DIFFERENTIAL PRESSURE SENSING VALVE, 160 PSI
12	1	SD307	COMPLETE MANIFOLD

FIGURE 26
TRUCK MOUNT KIT

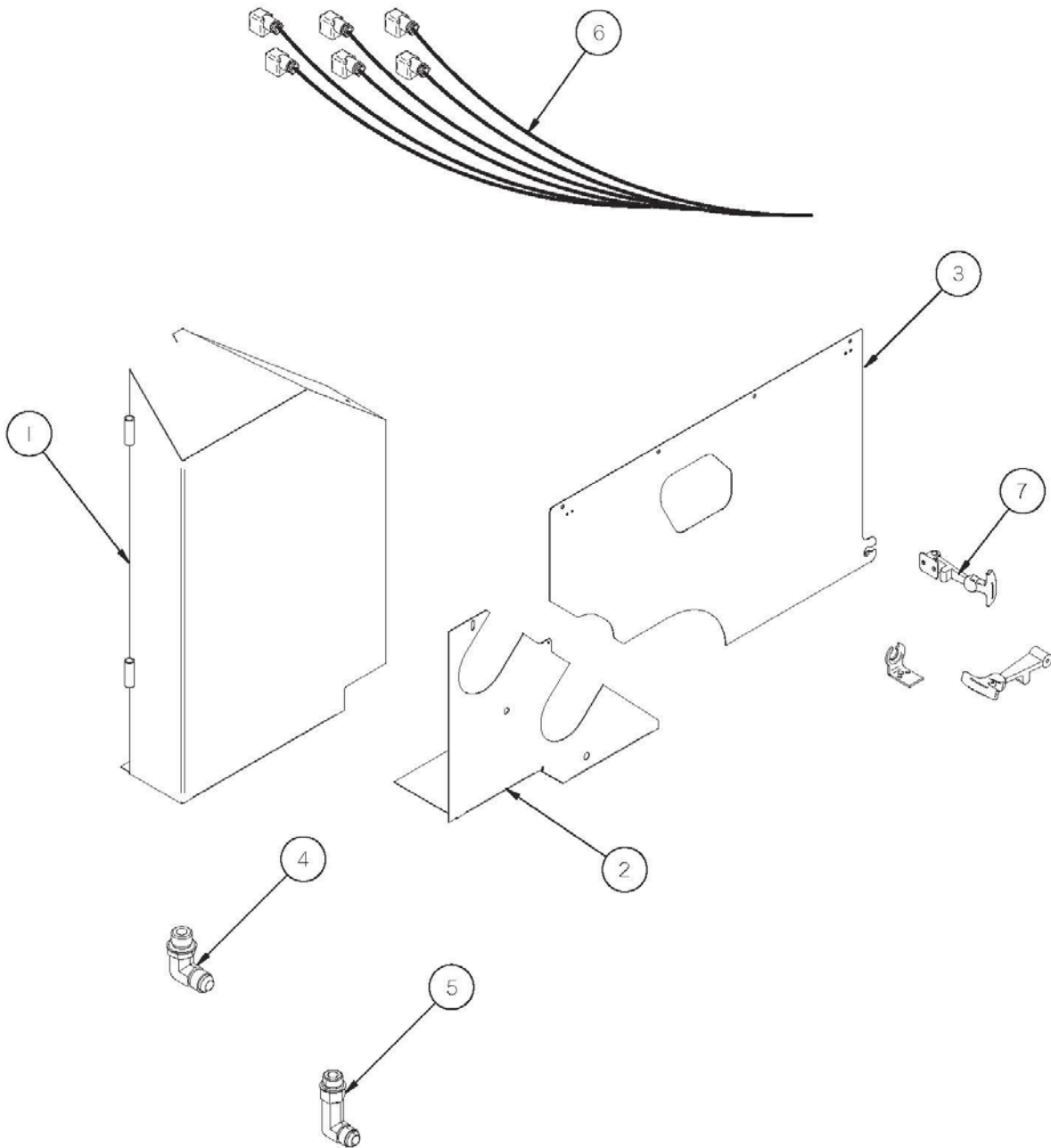

FIGURE 26

TRUCK MOUNT KIT

<u>ITEM</u>	<u>QTY</u>	<u>PART #</u>	<u>DESCRIPTION</u>
1	1	57496	FRONT CORNER SHIELD, TRUCK
2	1	57505	FRONT SHIELD LOWER, TRUCK
3	1	57498	VALVE SHIELD FACE, TRUCK
4	1	57517	10 90 DEG ELBOW
5	1	57520	10 90 DEG ELBOW LONG
6	1	8597	UNIT HARNESS TRUCK MOUNT
7	1	X233	COMPLETE LATCH

H&S MFG. CO.

products approved

for the

FEMA

SEAL OF QUALITY

